

KS Series Steam Spray Nozzles

KS

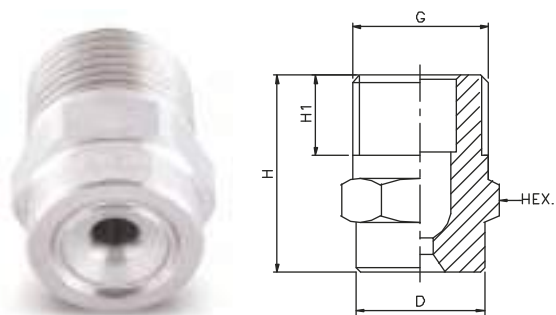

KS Series : 3/8" & 1/2"

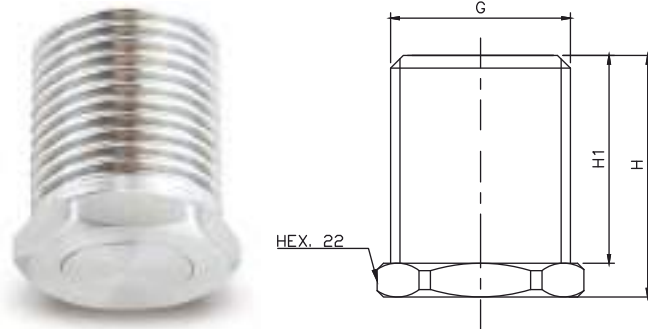

KS1 Series : 3/4" & 1/2"

'Spraytech' make KS series steam spray nozzles offers various capacities of mass flow rate for saturated and superheated steam which is widely used for applications such as steam purging, heating, humidification, sterilization etc.

KS series are available with inbuilt NRV design which allows the nozzle to work in immersible conditions. It opens when pressure is applied and locks itself when there is no pressure.

Available in two body designs, Standard (KS) and Full Threading (KS1)

Note: Designs are available with and without NRV features, please mention while ordering.



MODEL NO	END CONNECTION			MASS FLOW RATE OF SAT. STREAM (kg/hr)					G/A DIMENSION MM				
				Pressure [bar]									
	3/8"	1/2"	3/4"	1	2	3	4	5	CONN.	H	H1	D	HEX
KS.03	●			8.3	11.4	15.48	19.80	23.04	3/8"	25	10	16	17
KS.04	●			10.6	15.3	21.60	27.36	32.40	Weight (Metals) = XX gms. Approx				
KS.05	●	●		16.4	21.6	30.96	39.60	46.44	1/2"	32	13.2	21	22
KS.08	KS1.08	●		31.8	47.71	63.61	79.51	95.42	Weight (Metals) = XX gms. Approx				
KS.13	KS1.13		●	83.9	125.9	167.7	209.6	251.5	3/4"	42	15	32	27
	KS1.12		●	127.2	190.8	256.4	318.0	381.6	Weight (Metals) = XX gms. Approx				
	KS1.12		●	161.0	241.5	322.0	402.5	483.0					

End Connection : X – BSP, Y – BSPT, Z – NPT Available.

