

PART NO	PART NAME	QTY.
1	AIR CAP	01
2	LIQUID NOZZLE	01
3	HEAD BLOCK	01
4	CHAMBER BLOCK	01
5	NEEDLE GLAND	02
6	CYLINDER	01
7	PISTON	01
8	NEEDLE ASSEMBLY	01
9	NEEDLE SPRING	01
10	CYLINDER EXTENSION	01
11	PISTON SPRING	01
12	CYLINDER EXTENSION CAP	01

PART NO	'O'RING PART REFERENCE	QTY.
A	HEAD BLOCK (ATOM AIR SEALING)	01
B	HEAD BLOCK (LIQUID SEALING)	01
C	CHAMBER BLOCK (FACE SEALING)	01
D	CHAMBER BLOCK CYL. AIR INLET	01
E	CHAMBER BLOCK LIQUID INLET	01
F	NEEDLE GLAND	02
G	CYLINDER	01
H	CYLINDER (CYL. AIR SEALING)	01
I	PISTON	01
J	CYLINDER EXTENSION	02

1 SET = 12 NOS 'O' RING

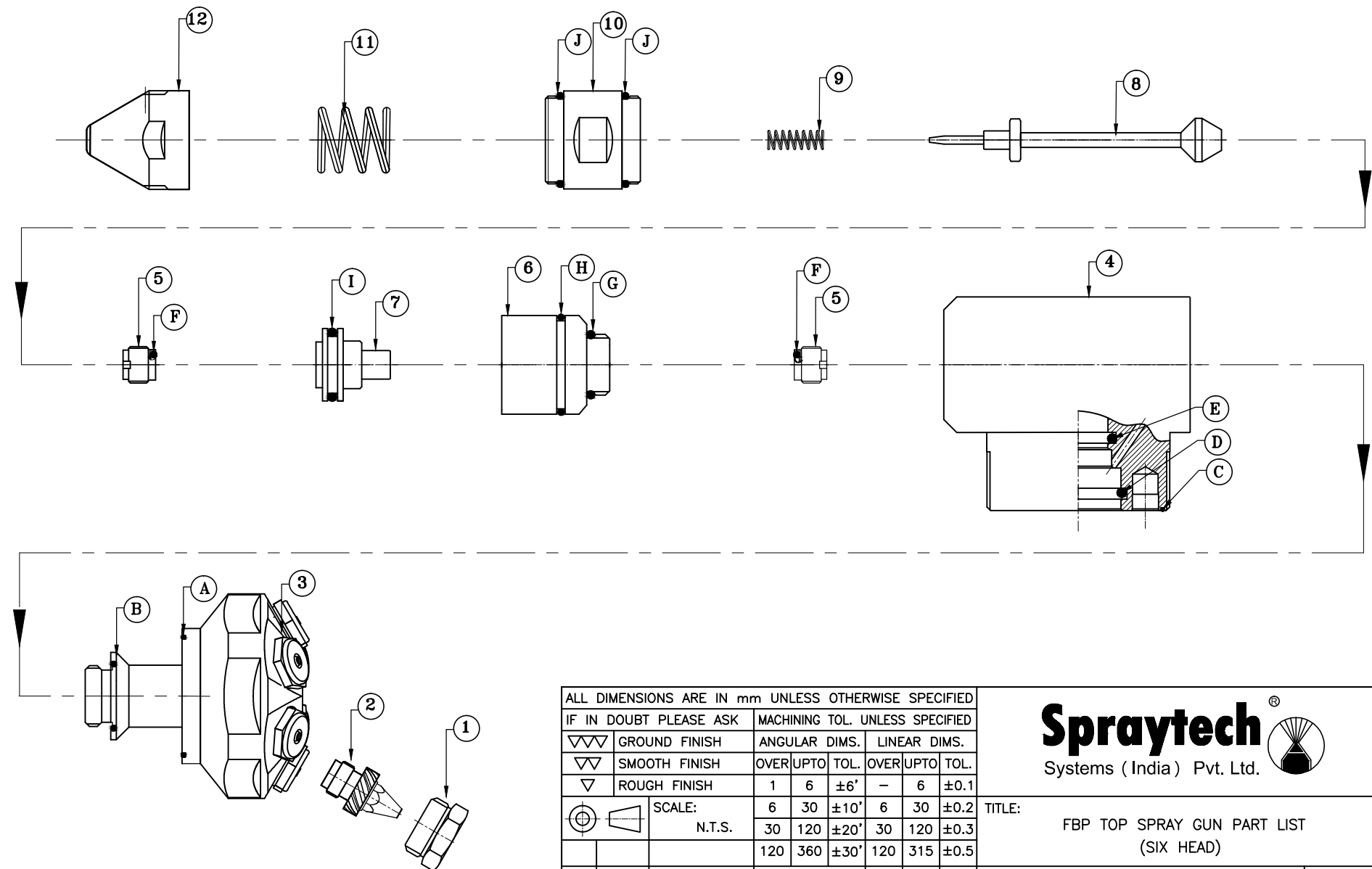
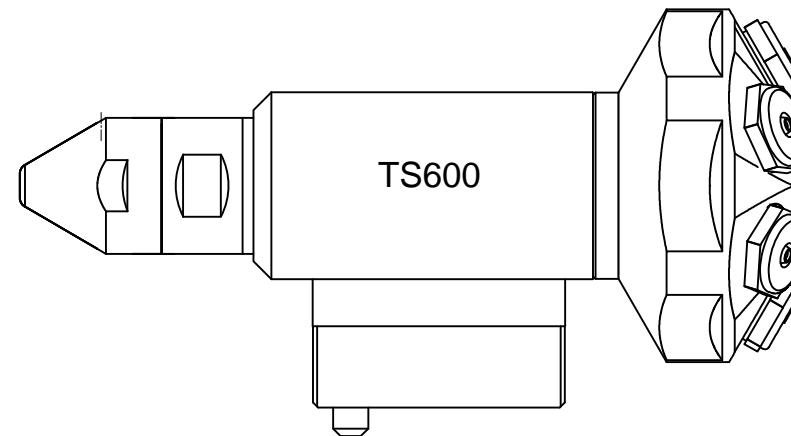

ALL DIMENSIONS ARE IN mm UNLESS OTHERWISE SPECIFIED							
IF IN DOUBT PLEASE ASK		MACHINING TOL. UNLESS SPECIFIED					
▽▽▽	GROUND FINISH	ANGULAR DIMS.		LINEAR DIMS.			
▽▽	SMOOTH FINISH	OVER	UPTO	TOL.	OVER	UPTO	TOL.
▽	ROUGH FINISH	1	6	±6'	-	6	±0.1
⊕	SCALE:	6	30	±10'	6	30	±0.2
	N.T.S.	30	120	±20'	30	120	±0.3
		120	360	±30'	120	315	±0.5
		M.O.C.:	SS316L	315	1000	±0.8	
		DRN.	ARTI	DATE	02/08/17		
		CHK.	RUSHI	SIGN			
REV	DATE	DESCRIPTION	APPD.	B.A.K.	SIGN		



TITLE: FBP TOP SPRAY GUN PART LIST (SIX HEAD)	
MODEL NO: TS600	PAGE: 1 OF 1
DWG. NO.: SPR.TSL.PL.08.17	REV.: 0

This document is property of M/s. SPRAYTECH SYSTEMS (INDIA) PVT. LTD. Passing on and copying of this document, Utilization and communication of its contents are prohibited unless expressly authorized. Offenders will be liable for damages.