



AN ISO 9001 : 2015 Certified Company

CIN No : U29219MH2006PTC163469



Decide with Confidence

D&B D-U-M-88 Number : 92-003-8427

PRETREATMENT SPRAY NOZZLES AND FITTINGS



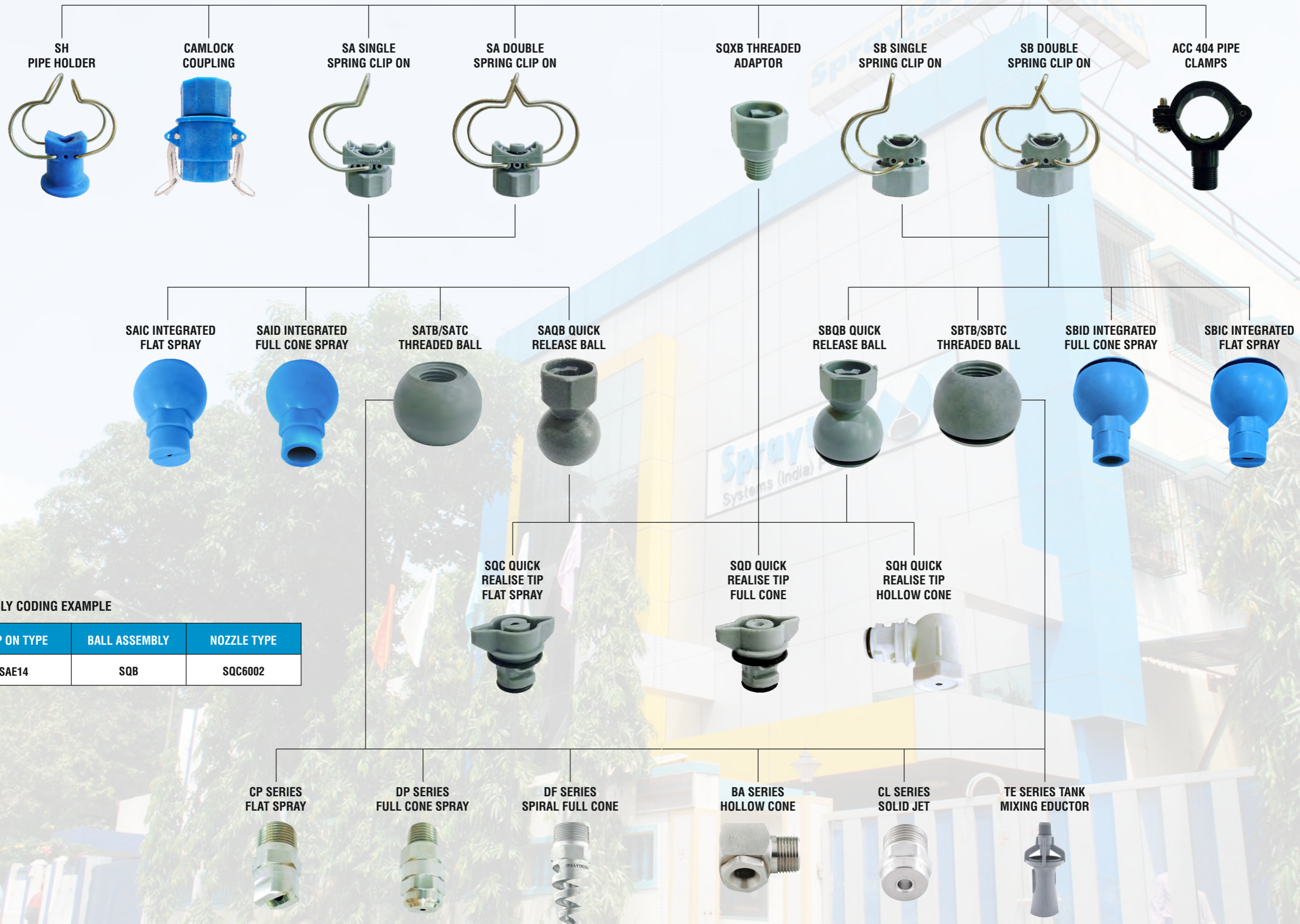

ASSEMBLY CODING EXAMPLE

CLIP ON TYPE	BALL ASSEMBLY	NOZZLE TYPE
SAE14	SQB	SQC6002

NEW DESIGN

SWIVEL CLIP ON NOZZLES

SA series swivel clamps are specially designed swivel clip on nozzles. To install SA series swivel nozzle assembly on pipes all you need is drill a hole of 14 mm or 16 mm (selecting the model), insert the nozzle body inside and clamp it. This is a robust, easy to install, adjust and service design and it is designed for modern surface pre-treatment plants. They provide excellent performance and easy maintenance.

Typical application : Used in pre-treatment process, industrial washing Machines and various processes.

Max working temperature : 80°C

Swivel Degree : 40°

Recommended working pressure : Single spring : 3 bar
Double spring : 5 bar

Materials

Body : Polypropylene (20% - 25% glass filled)

Clamp : SS 304 / SS 316

O-ring : (NBR) Nitrile Rubber, FKM (Viton®)



Single Clamp



Double Clamp

CODE		PIPE SIZE (inch)	PIPE OD (mm)	SUITABLE HOLE DIA (mm)
Single Clamp	Double Clamp			
SAE14	SAE24	3/4"	26.7	14
SAF14	SAF24	1"	33.4	14
SAG14	SAG24	1 1/4"	42.2	14
SAH14	SAH24	1 1/2"	48.3	14
SAK14	SAK26	2"	60.3	14
SAE16	SAE26	3/4"	26.7	16
SAF16	SAF26	1"	33.4	16
SAG16	SAG26	1 1/4"	42.2	16
SAH16	SAH26	1 1/2"	48.3	16
SAK16	SAK26	2"	60.3	16
SAE18	SAE28	3/4"	26.7	18
SAF18	SAF28	1"	33.4	18
SAG18	SAG28	1 1/4"	42.2	18
SAH18	SAH28	1 1/2"	48.3	18
SAK18	SAK28	2"	60.3	18

PLASTIC SWIVEL BALL NOZZLES

Integrated flat swivel ball spray nozzles are designed for diversified applications. They can be easily adjusted for spray pattern orientation and offer a quick-fit connection. Also available in various flow rates and spray angles with colour coding. Suitable for SA series clip on clamp.

Spray pattern : Flat spray

Typical application : Pre-treatment process, Semi conductor industry

Material : Glass filled PP

**NEW DESIGN**

MODEL NO				PRESSURE (BAR)					COLOR
45°	60°	90°	120°	0.5	1	2	3	4	
SAIC4501	SAIC6001	SAIC9001	SAIC1201	0.50	0.71	1.00	1.22	1.41	White
SAIC4502	SAIC6002	SAIC9002	SAIC1202	1.00	1.41	2.00	2.45	2.83	Grey
SAIC4504	SAIC6004	SAIC9004	SAIC1204	2.00	2.83	4.00	4.90	5.66	Beige
SAIC4506	SAIC6006	SAIC9006	SAIC1206	3.25	4.60	6.50	7.96	9.19	L. Blue
SAIC4508	SAIC6008	SAIC9008	SAIC1208	4.00	5.66	8.00	9.80	11.31	Red
SAIC4510	SAIC6010	SAIC9010	SAIC1210	5.00	7.07	10.00	12.25	14.14	Orange
SAIC4512	SAIC6012	SAIC9012	SAIC1212	6.25	8.84	12.50	15.31	17.68	Green
SAIC4516	SAIC6016	SAIC9016	SAIC1216	8.00	11.31	16.00	19.60	22.63	Yellow
SAIC4520	SAIC6020	SAIC9020	SAIC1220	10.00	14.14	20.00	24.49	28.28	D. Blue

PLASTIC SWIVEL BALL NOZZLES

Integrated Full cone swivel ball spray nozzles are designed for diversified applications. They can be easily adjusted for spray pattern orientation and offer a quick-fit connection. Also available in various flow rates and spray angles with colour coding. Suitable for SA series swivel clip on clamp.

Spray pattern : Full Cone

Typical application : Pre-treatment process, Semi conductor industry

Material : Glass filled PP

**NEW DESIGN**

MODEL NO				PRESSURE (BAR)					COLOR
45°	60°	90°	120°	0.5	1	2	3	4	
SAID4501	SAID6001	SAID9001	SAID1201	0.50	0.71	1.00	1.22	1.41	White
SAID4502	SAID6002	SAID9002	SAID1202	1.00	1.41	2.00	2.45	2.83	Grey
SAID4504	SAID6004	SAID9004	SAID1204	2.00	2.83	4.00	4.90	5.66	Beige
SAID4506	SAID6006	SAID9006	SAID1206	3.25	4.60	6.50	7.96	9.19	L. Blue
SAID4508	SAID6008	SAID9008	SAID1208	4.00	5.66	8.00	9.80	11.31	Red
SAID4510	SAID6010	SAID9010	SAID1210	5.00	7.07	10.00	12.25	14.14	Orange
SAID4512	SAID6012	SAID9012	SAID1212	6.25	8.84	12.50	15.31	17.68	Green
SAID4516	SAID6016	SAID9016	SAID1216	8.00	11.31	16.00	19.60	22.63	Yellow
SAID4520	SAID6020	SAID9020	SAID1220	10.00	14.14	20.00	24.49	28.28	D. Blue

SWIVEL CLIP ON NOZZLES

SB series swivel clamps are specially designed swivel clip on nozzles with 'O' ring for maximum sealing. To install SB series swivel nozzle assembly on pipes all you need is drill a hole of 14 mm or 18 mm (selecting the model), insert the nozzle body inside and clamp it. This easy to install, adjust and service design and it is designed for modern surface pre-treatment plants. They provide excellent performance and easy maintenance.

Typical application : Used in pre-treatment process, industrial washing Machines and various processes.

Max working temperature : 80°C

Swivel Degree : 40°

Recommended working pressure : Single spring : 3 bar
Double spring : 5 bar

Materials

Body : Polypropylene (20% - 25% glass filled)

Clamp : SS 304 / SS 316

O-ring : (NBR) Nitrile Rubber, FKM (Viton®)

**Single Clamp****Double Clamp**

CODE		PIPE SIZE (inch)	PIPE OD (mm)	SUITABLE HOLE DIA (mm)
Single Clamp	Double Clamp			
SBE14	SBE24	3/4"	26.7	14
SBF14	SBF24	1"	33.4	14
SBG14	SBG24	1 1/4"	42.2	14
SBH14	SBH24	1 1/2"	48.3	14
SBK14	SBK26	2"	60.3	14
SBE16	SAE26	3/4"	26.7	16
SBF16	SBF26	1"	33.4	16
SBG16	SBG26	1 1/4"	42.2	16
SBH16	SBH26	1 1/2"	48.3	16
SBK16	SBK26	2"	60.3	16
SBE18	SBE28	3/4"	26.7	18
SBF18	SBF28	1"	33.4	18
SBG18	SBG28	1 1/4"	42.2	18
SBH18	SBH28	1 1/2"	48.3	18
SBK18	SBK28	2"	60.3	18

PLASTIC SWIVEL BALL NOZZLES

Integrated flat swivel ball spray nozzles are designed for diversified applications. They can be easily adjusted for spray pattern orientation and offer a quick-fit connection. Also available in various flow rates and spray angles with colour coding. Suitable for SA series clip on clamp.

Spray pattern : Flat spray

Typical application : Pre-treatment process, Semi conductor industry

Material : Glass filled PP



MODEL NO				PRESSURE (BAR)					COLOR
45°	60°	90°	120°	0.5	1	2	3	4	
SBIC4501	SBIC6001	SBIC9001	SBIC1201	0.50	0.71	1.00	1.22	1.41	White
SBIC4502	SBIC6002	SBIC9002	SBIC1202	1.00	1.41	2.00	2.45	2.86	Grey
SBIC4504	SBIC6004	SBIC9004	SBIC1204	2.00	2.83	4.00	4.90	5.66	Beige
SBIC4506	SBIC6006	SBIC9006	SBIC1206	3.25	4.60	6.50	7.96	9.19	L. Blue
SBIC4508	SBIC6008	SBIC9008	SBIC1208	4.00	5.66	8.00	9.80	11.31	Red
SBIC4510	SBIC6010	SBIC9010	SBIC1210	5.00	7.07	10.00	12.25	14.14	Orange
SBIC4512	SBIC6012	SBIC9012	SBIC1212	6.03	8.84	12.50	15.31	17.68	Green
SBIC4516	SBIC6016	SBIC9016	SBIC1216	8.00	11.31	16.00	19.60	22.63	Yellow
SBIC4520	SBIC6020	SBIC9020	SBIC1220	10.00	14.14	20.00	24.49	28.28	D. Blue

PLASTIC SWIVEL BALL NOZZLES

Integrated Full cone swivel ball spray nozzles are designed for diversified applications. They can be easily adjusted for spray pattern orientation and offer a quick-fit connection. Also available in various flow rates and spray angles with colour coding. Suitable for SA series swivel clip on clamp.

Spray pattern : Full Cone

Typical application : Pre-treatment process, Semi conductor industry

Material : Glass filled PP



MODEL NO				PRESSURE (BAR)					COLOR
45°	60°	90°	120°	0.5	1	2	3	4	
SBID4501	SBID6001	SBID9001	SBID1201	0.50	0.71	1.00	1.22	1.41	White
SBID4502	SBID6002	SBID9002	SBID1202	1.00	1.41	2.00	2.45	2.83	Grey
SBID4504	SBID6004	SBID9004	SBID1204	2.00	2.83	4.00	4.90	5.66	Beige
SBID4506	SBID6006	SBID9006	SBID1206	3.25	4.60	6.50	7.96	9.19	L. Blue
SBID4508	SBID6008	SBID9008	SBID1208	4.00	5.66	8.00	9.80	11.31	Red
SBID4510	SBID6010	SBID9010	SBID1210	5.00	7.07	10.00	12.25	14.14	Orange
SBID4512	SBID6012	SBID9012	SBID1212	6.25	8.84	12.50	15.31	17.68	Green
SBID4516	SBID6016	SBID9016	SBID1216	8.00	11.31	16.00	19.60	22.63	Yellow
SBID4520	SBID6020	SBID9020	SBID1220	10.00	14.14	20.00	24.49	28.28	D. Blue

SQXB / SQXC

QUICK RELEASE ADAPTOR THREADED TYPE

Quick release threaded adaptor suitable for quick release nozzle tip.
Size: 1/4" BSP (M)

Materials

Glass filled PP

MODEL NO.	SIZE (G) BSP (M)	H mm	HEX mm
SQXB	1/4"	32.5	22
SQXC	3/8"	32.5	22



SAQB

SWIVEL BALL QUICK RELEASE TYPE ADAPTOR

Swivel ball quick release type suitable for SA series clip on assembly and Quick release spray tips.

NEW DESIGN

Materials

Glass filled PP

MODEL NO.
SAQB



Suitable for SA series

SBQB

SWIVEL BALL QUICK RELEASE TYPE ADAPTOR

Swivel ball quick release type suitable for SA series clip on assembly and Quick release spray tips.

Materials

Glass filled PP

MODEL NO.
SBQB



Suitable for SB series

SQC

QUICK RELEASE TIP (FLAT SPRAY)

SQC series polypropylene spray nozzles provide for easy change-out on the run. The nozzle can be removed in seconds with a quarter turn without the use of tools.

SQC series are available in Flat Spray patterns and produce uniform distribution of small, medium and large size droplets. Suitable for SA series swivel ball quick release type and quick release threaded adapter.

Materials

Glass filled PP



Suitable for
SA & SB series

MODEL NO				PRESSURE (BAR)					COLOR
45°	60°	90°	120°	0.5	1	2	3	4	
SQC4501	SQC6001	SQC9001	SQC1201	0.50	0.71	1.00	1.22	1.41	White
SQC4502	SQC6002	SQC9002	SQC1202	1.00	1.41	2.00	2.45	2.86	Grey
SQC4504	SQC6004	SQC9004	SQC1204	2.00	2.83	4.00	4.90	5.66	Beige
SQC4506	SQC6006	SQC9006	SQC1206	3.25	4.60	6.50	7.96	9.19	L. Blue
SQC4508	SQC6008	SQC9008	SQC1208	4.00	5.66	8.00	9.80	11.31	Red
SQC4510	SQC6010	SQC9010	SQC1210	5.00	7.07	10.00	12.25	14.14	Orange
SQC4512	SQC6012	SQC9012	SQC1212	6.25	8.84	12.50	15.31	17.68	Green
SQC4516	SQC6016	SQC9016	SQC1216	8.00	11.31	16.00	19.60	22.63	Yellow
SQC4520	SQC6020	SQC9020	SQC1220	10.00	14.14	20.00	24.49	28.28	D. Blue

SQD

QUICK RELEASE TIP (FULL CONE)

SQD series polypropylene spray nozzles provide for easy change-out on the run. The nozzle can be removed in seconds with a quarter turn without the use of tools.

SQD series are available in Full Cone Spray patterns and produce uniform distribution of small, medium and large size droplets. Suitable for SA & SB series swivel ball quick release type and quick release threaded adapter.

Materials

Glass filled PP



Suitable for
SA & SB series

MODEL NO				PRESSURE (BAR)					COLOR
45°	60°	90°	120°	0.5	1	2	3	4	
SQD4501	SQD6001	SQD9001	SQD1201	0.50	0.71	1.00	1.22	1.41	White
SQD4502	SQD6002	SQD9002	SQD1202	1.00	1.41	2.00	2.45	2.86	Grey
SQD4504	SQD6004	SQD9004	SQD1204	2.00	2.83	4.00	4.90	5.66	Beige
SQD4506	SQD6006	SQD9006	SQD1206	3.25	4.60	6.50	7.96	9.19	L. Blue
SQD4508	SQD6008	SQD9008	SQD1208	4.00	5.66	8.00	9.80	11.31	Red
SQD4510	SQD6010	SQD9010	SQD1210	5.00	7.07	10.00	12.25	14.14	Orange
SQD4512	SQD6012	SQD9012	SQD1212	6.25	8.84	12.50	15.31	17.68	Green

SQH series polypropylene spray nozzles provide for easy change-out on the run. The nozzle can be removed in seconds with a quarter turn without the use of tools.

SQH series are available in Hollow Cone Spray patterns and produce uniform distribution of small, medium and large size droplets. Suitable for SA series swivel ball quick release type and quick release threaded adapter.



**Suitable for
SA & SB series**

Materials

Glass filled PP

MODEL NO			PRESSURE (BAR)					COLOR
60°	90°	120°	0.5	1	2	3	4	
SQH6001	SQH9001	SQC1201	0.50	0.71	1.00	1.22	1.41	White
SQH6002	SQH9002	SQH1202	1.00	1.41	2.00	2.45	2.86	Grey
SQH6004	SQH9004	SQH1204	2.00	2.83	4.00	4.90	5.66	Beige
SQH6006	SQH9006	SQH1206	3.25	4.60	6.50	7.96	9.19	L. Blue
SQH6008	SQH9008	SQH1208	4.00	5.66	8.00	9.80	11.31	Red
SQH6010	SQH9010	SQH1210	5.00	7.07	10.00	12.25	14.14	Orange
SQH6012	SQH9012	SQH1212	6.25	8.84	12.50	15.31	17.68	Green
SQH6016	SQH9016	SQH1216	8.00	11.31	16.00	19.60	22.63	Yellow
SQH6020	SQH9020	SQH1220	10.00	14.14	20.00	24.49	28.28	D. Blue

SATB / SATC / SBTB / SBTC

SWIVEL BALL THREADED TYPE

SWIVEL BALL THREADED TYPE

STB & STC series swivel threaded ball are available in 1/4" & 3/8". These can be assembled with SA series clip on assemblies. The threaded nozzles DA, CA, BA series can be used with STB & STC threaded swivel ball.



Suitable for SA series

MODEL NO.	SIZE (BSPP)
SATB	1/4" (F)
SATC	3/8" (F)



Suitable for SB series

MODEL NO.	SIZE (BSPP)
SBTB	1/4" (F)
SBTC	3/8" (F)

NEW DESIGN

BM

TANGENTIAL ENTRY HOLLOW CONE SPRAY NOZZLE

Uniform hollow cone spray at low pressure.
Best suitable for cooling towers.

Size : 1/2" BSP (F)
3/4" BSP (F)
1" BSP (F)

Spray angle : 60° to 90°
Materials : Glass filled PP
Colour : Black

**BN**

TANGENTIAL ENTRY HOLLOW CONE SPRAY NOZZLE (CLIP ON TYPE)

Uniform hollow cone spray pattern with fine droplets.

Application: Cooling tunnel, Pasteurizer
Size: suitable for 1" pipe
Spray angle : 90°
Materials : Glass filled PP
Colour: D blue, Red

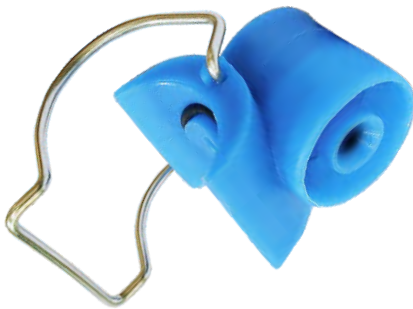

ACC 350 END CAPS

ACC350 plastic caps are best suitable to plug pipes ends also it can be used to seal pipes ends when, to manufacture different size products, it is made of glass filled polypropylene offer the best resistance to chemicals. They are widely used in surface pre-treatment.

Max working temperature 80°C.

Materials

Polypropylene (20% - 25% glass filled)

MODEL NO.	SIZE (G) BSPP	H (mm)	OCTAGON (mm)
ACC350.P2G.XF	1"	25	42
ACC350.P2G.XG	1 1/4"	28	52
ACC350.P2G.XH	1 1/2"	32	60

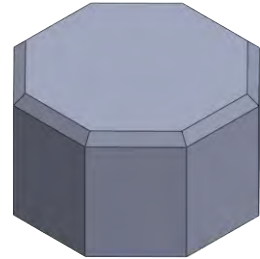
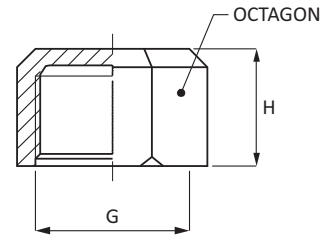

ACC 404 PIPE CLAMPS (MALE THREADED)

Easy to clamp on pipe of various sizes. suitable to install nozzles/adaptors of female threads.

Materials : Glass filled PP

Colour: Black

MODEL NO.	SIZE
ACC404.P2G.XC.D	1/2"
ACC404.P2G.XC.E	3/4"
ACC404.P2G.XC.F	1"
ACC404.P2G.XC.G	1-1/4"



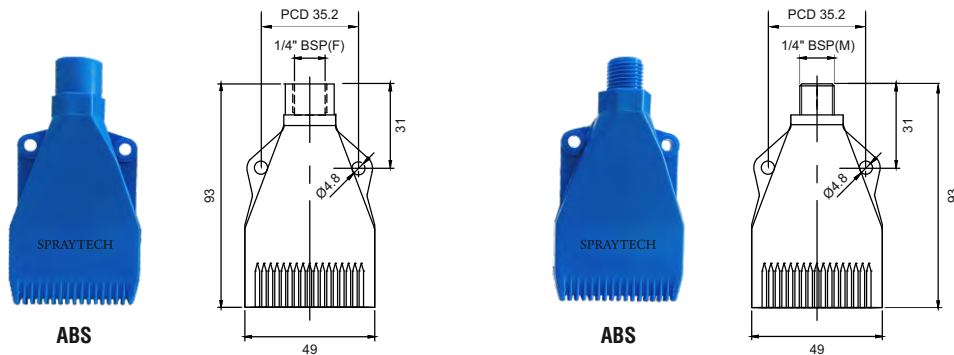

Multi channel flat air spray nozzle have been specially designed for high impact of compressed air with attenuate noise, to obtain an intensive, precise blowing power to minimize cost by reducing air consumption.

Max working temperature 60°C.

Materials

ABS

MODEL NO.	END CONNECTION		ORIFICE SIZE (mm)	FLOW CAPACITY IN Nm ³ /hr AT DIFFERENT PRESSURE				WEIGHT
	1/4"			PRESSURE [BAR]				
	BSP (M)	BSP (F)		1	2	3	4	
CJ08.P11.XBM	●		0.8	16	22	27	31	MALE : Weight = 18 gms. Approx FEMALE : Weight = 16 gms. Approx
CJ08.P11.XBF		●	0.8	16	22	27	31	
CJ10.P11.XBM	●		1.0	16	22	27	31	
CJ10.P11.XBF		●	1.0	16	22	27	31	

Spraytech CM Series Spray nozzles work equally effectively. The nozzles give a sharp, defined, fan shaped water jet providing efficient cleaning. Spraytech Spray nozzles are ideal for washing, dust control and deslurrying applications. Spraytech Spray nozzles made from polyurethane ensure efficient cleaning.

Features : Uniform spray pattern, Coarse flat fan spray,
Tough wear resistant, One piece molded construction,
Corrosion-resistant, Economical

MODEL NO	ORIFICE (mm)	COLOUR	END CONNECTION
CM03.P9.XE	3.0	Grey	3/4" BSP (M)
CM05.P9.XE	5.0	Green	3/4" BSP (M)
CM07.P9.XE	7.0	Blue	3/4" BSP (M)
CM09.P9.XE	9.0	Yellow	3/4" BSP (M)
CM11.P9.XE	11.0	Red	3/4" BSP (M)

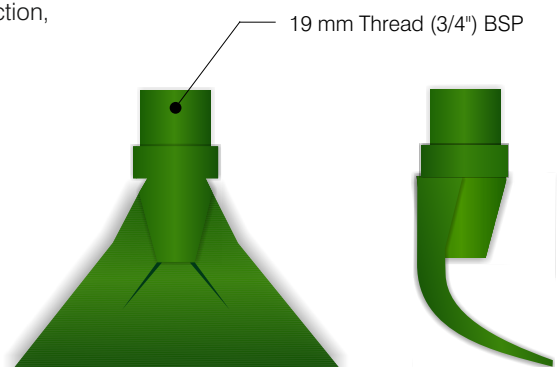

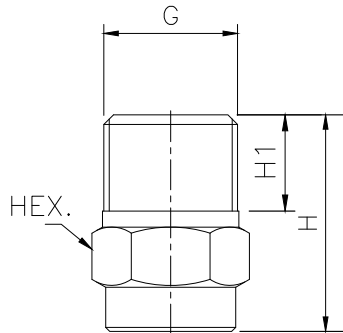

DA series Full Cone Spray Nozzle form complete spray coverage in a round area. It provides an uniform spray distribution of medium to large size drops resulting from their vane design which features large flow passage and control characteristics.

MODEL NO.	END CONNECTION		ORIFICE SIZE (mm)	FLOW CAPACITY IN LPM AT DIFFERENT PRESSURE							G/A DIMENSION. MM			
	1/4"	3/8"		PRESSURE [BAR]										
SPRAY ANGLE	BSP	BSP												
45°				0.5	1.0	2.0	3.0	5.0	7.0	10.0	CONN.	H	H1	HEX
DA13.250	•		1.9	1.25	1.77	2.50	3.06	3.95	4.68	5.59	1/4"	25	9.7	15.5
DA13.300	•		2.0	1.50	2.12	3.00	3.67	4.74	5.61	6.71	Weight = XX gms. Approx			
DA13.350	•	•	2.2	1.75	2.47	3.50	4.29	5.53	6.55	7.83	3/8"	27	12	17
DA13.400	•	•	2.4	2.00	2.83	4.00	4.90	6.32	7.48	8.94	Weight = XX gms. Approx			
DA13.475	•	•	2.6	2.37	3.36	4.75	5.82	7.51	8.89	10.62				
DA13.650		•	3.1	3.25	4.60	6.50	7.96	10.28	12.16	14.53				

MODEL NO.	END CONNECTION		ORIFICE SIZE (mm)	FLOW CAPACITY IN LPM AT DIFFERENT PRESSURE							G/A DIMENSION. MM			
	1/4"	3/8"		PRESSURE [BAR]										
SPRAY ANGLE	BSP	BSP												
60°				0.5	1.0	2.0	3.0	5.0	7.0	10.0	CONN.	H	H1	HEX
DA14.350	•		2.2	1.75	2.47	3.50	4.29	5.53	6.55	7.83	1/4"	25	9.7	15.5
DA14.400	•	•	2.4	2.00	2.83	4.00	4.90	6.32	7.48	8.94	Weight = XX gms. Approx			
DA14.475	•	•	2.6	2.37	3.36	4.75	5.82	7.51	8.89	10.62	3/8"	27	12	17
DA14.650	•	•	3.1	3.25	4.60	6.50	7.96	10.28	12.16	14.53	Weight = XX gms. Approx			
DA14.800		•	3.4	4.00	5.66	8.00	9.80	12.65	14.97	17.89				
DA24.100		•	3.8	5.00	7.07	10.0	12.25	15.81	18.71	22.36				

MODEL NO.	END CONNECTION		ORIFICE SIZE (mm)	FLOW CAPACITY IN LPM AT DIFFERENT PRESSURE							G/A DIMENSION. MM			
	1/4"	3/8"		PRESSURE [BAR]										
SPRAY ANGLE	BSP	BSP												
90°				0.5	1.0	2.0	3.0	5.0	7.0	10.0	CONN.	H	H1	HEX
DA16.350	•	•	2.2	1.75	2.47	3.50	4.29	5.53	6.55	7.83	1/4"	25	9.7	15.5
DA16.400	•	•	2.3	2.00	2.83	4.00	4.90	6.32	7.48	8.94	Weight = XX gms. Approx			
DA16.475	•	•	2.5	2.37	3.36	4.75	5.82	7.51	8.89	10.62	3/8"	27	12	17
DA16.650	•	•	2.9	3.25	4.60	6.50	7.96	10.28	12.16	14.53	Weight = XX gms. Approx			
DA16.800	•	•	3.3	4.00	5.66	8.00	9.80	12.65	14.97	17.89				
DA26.100		•	3.6	5.00	7.07	10.00	12.25	15.81	18.71	22.36				
DA26.125		•	4.1	6.25	8.84	12.50	15.31	19.76	23.39	27.95				
DA26.160		•	4.6	8.00	11.31	16.00	19.60	25.30	29.93	35.78				

MODEL NO.	END CONNECTION		ORIFICE SIZE (mm)	FLOW CAPACITY IN LPM AT DIFFERENT PRESSURE							G/A DIMENSION. MM			
	1/4"	3/8"		PRESSURE [BAR]										
SPRAY ANGLE	BSP	BSP												
120°				0.5	1.0	2.0	3.0	5.0	7.0	10.0	CONN.	H	H1	HEX
DA18.400	•	•	2.5	2.00	2.83	4.00	4.90	6.32	7.48	8.94	1/4"	25	9.7	15.5
DA18.475	•	•	2.7	2.37	2.36	4.75	5.82	7.51	8.89	10.62	Weight = XX gms. Approx			
DA18.650	•	•	3.1	3.25	4.60	6.50	7.96	10.28	12.16	14.53	3/8"	27	12	17
DA18.800	•	•	3.5	4.00	5.66	8.00	9.80	12.65	14.97	17.89	Weight = XX gms. Approx			
DA28.100		•	3.9	5.00	7.07	10.00	12.25	15.81	18.71	22.36				
DA28.125		•	4.3	6.25	8.84	12.50	15.31	19.76	23.39	27.95				
DA28.160		•	4.9	8.00	11.31	16.00	19.60	25.30	29.93	35.78				

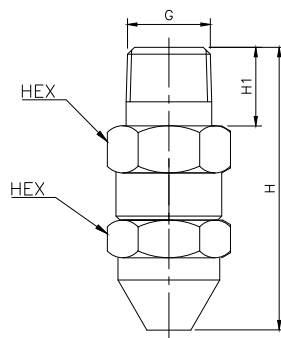

Spray Angle : 15° & 30°

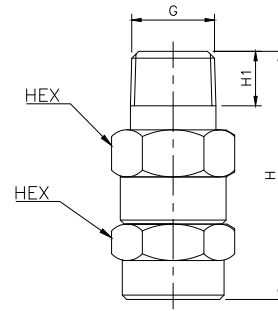

Spray Angle : 45°, 60°, 90° & 120°

DP series Full Cone Spray Nozzle form complete spray coverage in a round area. It provides an uniform spray distribution of medium to large size drops resulting from their vane design which features large flow passage and control characteristics.

Characteristic : Internal vane design features large flow passage and fine control.

Design : Removable vane, Axial flow.

Type : Round pattern, Threaded connection.

MODEL NO.		END CONNECTION		ORIFICE SIZE (mm)	FLOW CAPACITY IN LPM AT DIFFERENT PRESSURE							G/A DIMENSION. MM			
		1/4"	3/8"		PRESSURE [BAR]										
SPRAY ANGLE		BSP	BSP									CONN.	H	H1	HEX
15°	30°														
DP11.475	DP12.475	●		2.7	0.5	1.0	2.0	3.0	5.0	7.0	10.62	1/4"	45	10	17
DP11.650	DP12.650	●		3.1	2.37	3.36	4.75	5.82	7.51	8.89	10.62	Weight (Metals) = XX gms. Approx			
DP11.800	DP12.800	●		3.5	3.25	4.60	6.50	7.96	10.28	12.16	14.53	3/8"	55.5	10	22
DP21.100	DP22.100	●	●	3.9	4.00	5.66	8.00	9.80	12.65	14.97	17.89	Weight (Metals) = XX gms. Approx			
DP21.125	DP22.125		●	4.3	5.00	7.07	10.00	12.25	15.81	18.71	22.36				
DP21.160	DP22.160		●	4.9	6.25	8.84	12.50	15.31	19.76	23.39	27.95				
					8.00	11.31	16.00	19.60	25.30	29.93	35.78				

MODEL NO.		END CONNECTION		ORIFICE SIZE (mm)	FLOW CAPACITY IN LPM AT DIFFERENT PRESSURE							G/A DIMENSION. MM			
		1/4"	3/8"		PRESSURE [BAR]										
SPRAY ANGLE		BSP	BSP									CONN.	H	H1	HEX
45°															
DP13.250		●		1.9	0.5	1.0	2.0	3.0	5.0	7.0	10.62	1/4"	39.5	10	17
DP13.300		●		2.0	1.25	1.77	2.50	3.06	3.95	4.68	5.59	Weight (Metals) = XX gms. Approx			
DP13.350		●	●	2.2	1.50	2.12	3.00	3.67	4.74	5.61	6.71	3/8"	47.0	10	22
DP13.400		●	●	2.4	1.75	2.47	3.50	4.29	5.53	6.55	7.83	Weight (Metals) = XX gms. Approx			
DP13.475		●	●	2.6	2.00	2.83	4.00	4.90	6.32	7.48	8.94				
DP13.650			●	3.1	2.37	3.36	4.75	5.82	7.51	8.89	10.62				
					3.25	4.60	6.50	7.96	10.28	12.16	14.53				

MODEL NO.	END CONNECTION		ORIFICE SIZE (mm)	FLOW CAPACITY IN LPM AT DIFFERENT PRESSURE							G/A DIMENSION. MM			
	1/4"	3/8"		PRESSURE [BAR]										
SPRAY ANGLE	BSP	BSP									CONN.	H	H1	HEX
60°				0.5	1.0	2.0	3.0	5.0	7.0	10.0				
DP14.350	•		2.2	1.75	2.47	3.50	4.29	5.53	6.55	7.83	1/4"	39.5	10	17
DP14.400	•	•	2.4	2.00	2.83	4.00	4.90	6.32	7.48	8.94	Weight (Metals) = XX gms. Approx			
DP14.475	•	•	2.6	2.37	3.36	4.75	5.82	7.51	8.89	10.62	3/8"	47.0	10	22
DP14.650	•	•	3.1	3.25	4.60	6.50	7.96	10.28	12.16	14.53	Weight (Metals) = XX gms. Approx			
DP14.800		•	3.4	4.00	5.66	8.00	9.80	12.65	14.97	17.89				
DP24.100		•	3.8	5.00	7.07	10.0	12.25	15.81	18.71	22.36				

MODEL NO.	END CONNECTION		ORIFICE SIZE (mm)	FLOW CAPACITY IN LPM AT DIFFERENT PRESSURE							G/A DIMENSION. MM			
	1/4"	3/8"		PRESSURE [BAR]										
SPRAY ANGLE	BSP	BSP									CONN.	H	H1	HEX
90°				0.5	1.0	2.0	3.0	5.0	7.0	10.0				
DP16.350	•		2.2	1.75	2.47	3.50	4.29	5.53	6.55	7.83	1/4"	39.5	10	17
DP16.400	•	•	2.3	2.00	2.83	4.00	4.90	6.32	7.48	8.94	Weight (Metals) = XX gms. Approx			
DP16.475	•	•	2.5	2.37	3.36	4.75	5.82	7.51	8.89	10.62	3/8"	47.0	10	22
DP16.650	•	•	2.9	3.25	4.60	6.50	7.96	10.28	12.16	14.53	Weight (Metals) = XX gms. Approx			
DP16.800	•	•	3.3	4.00	5.66	8.00	9.80	12.65	14.97	17.89				
DP26.100		•	3.6	5.00	7.07	10.0	12.25	15.81	18.71	22.36				
DP26.125		•	4.1	6.25	8.84	12.50	15.31	19.76	23.39	27.95				
DP26.160		•	4.6	8.00	11.31	16.00	19.60	25.30	29.93	35.78				

MODEL NO.	END CONNECTION		ORIFICE SIZE (mm)	FLOW CAPACITY IN LPM AT DIFFERENT PRESSURE							G/A DIMENSION. MM			
	1/4"	3/8"		PRESSURE [BAR]										
SPRAY ANGLE	BSP	BSP									CONN.	H	H1	HEX
120°				0.5	1.0	2.0	3.0	5.0	7.0	10.0				
DP18.400	•	•	2.5	2.00	2.83	4.00	4.90	6.32	7.48	8.94	1/4"	39.5	10	17
DP18.475	•	•	2.7	2.37	2.36	4.75	5.82	7.51	8.89	10.62	Weight (Metals) = XX gms. Approx			
DP18.650	•	•	3.1	3.25	4.60	6.50	7.96	10.28	12.16	14.53	3/8"	47.0	10	22
DP18.800	•	•	3.5	4.00	5.66	8.00	9.80	12.65	14.97	17.89	Weight (Metals) = XX gms. Approx			
DP28.100		•	3.9	5.00	7.07	10.00	12.25	15.81	18.71	22.36				
DP28.125		•	4.3	6.25	8.84	12.50	15.31	19.76	23.39	27.95				
DP28.160		•	4.9	8.00	11.31	16.00	19.60	25.30	29.93	35.78				

- Characteristic** : The absence of any internal parts make these nozzles non-clogging.
- Design** : One piece construction, non clogging type.
- Application** : PT Line, Washing Fighting Systems.
- Flow Rate** : 5 LPM TO 25 LPM
- Pressure** : 2.0 Kg/cm² or Specified
- Spray Angle** : 60° To 180°
- End Connection** : 1/4" TO 3/8"
- M.O.C.** : SS 316, 304, BRASS, PVDF, PVC, PP, PTFE

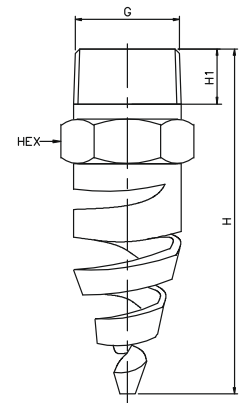

The helix spiral full cone nozzles combine small nozzle sizes with wide flow openings.

MODEL NO.	END CONNECTION	ORIFICE SIZE (mm)	FLOW CAPACITY IN LPM AT DIFFERENT PRESSURE							G/A DIMENSION. MM				
	1/4"		PRESSURE [BAR]							CONN.	H	H1	HEX	
SPRAY ANGLE 60°	BSP		0.5	1.0	2.0	3.0	5.0	7.0	10.0	1/4"	48	10	14	
DF14.475	•	2.4	2.37	3.36	4.75	5.82	7.51	8.89	10.62	Weight = XX gms. Approx				
DF14.650	•	2.8	3.25	4.60	6.50	7.96	10.28	12.16	14.53					
DF14.800	•	3.1	4.00	5.66	8.00	9.80	12.65	14.97	17.89					
DF24.100	•	3.5	5.00	7.07	10.00	12.25	15.81	18.71	22.36					
DF24.125	•	3.9	6.25	8.84	12.50	15.31	19.76	23.39	27.95					
DF24.160	•	4.4	8.00	11.31	16.00	19.60	25.30	29.93	35.78					
DF24.180	•	4.6	9.00	12.73	18.00	22.05	28.46	33.67	40.25					
DF24.200	•	4.9	10.00	14.14	20.00	24.49	31.62	37.42	44.72					
DF24.225	•	5.2	11.25	15.91	22.50	27.56	35.58	42.09	50.31					
DF24.250	•	5.5	12.50	17.68	25.00	30.62	39.53	46.77	55.90					

MODEL NO.	END CONNECTION	ORIFICE SIZE (mm)	FLOW CAPACITY IN LPM AT DIFFERENT PRESSURE							G/A DIMENSION. MM				
	1/4"		PRESSURE [BAR]							CONN.	H	H1	HEX	
SPRAY ANGLE 90°	BSP		0.5	1.0	2.0	3.0	5.0	7.0	10.0	1/4"	48	10	14	
DF16.475	•	2.4	2.37	3.36	4.75	5.82	7.51	8.89	10.62	Weight = XX gms. Approx				
DF16.650	•	2.8	3.25	4.60	6.50	7.96	10.28	12.16	14.53					
DF16.800	•	3.1	4.00	5.66	8.00	9.80	12.65	14.97	17.89					
DF26.100	•	3.5	5.00	7.07	10.00	12.25	15.81	18.71	22.36					
DF26.125	•	3.9	6.25	8.84	12.50	15.31	19.76	23.39	27.95					
DF26.160	•	4.4	8.00	11.31	16.00	19.60	25.30	29.93	35.78					
DF26.180	•	4.6	9.00	12.73	18.00	22.05	28.46	33.67	40.25					
DF26.200	•	4.9	10.00	14.14	20.00	24.49	31.62	37.42	44.72					
DF26.225	•	5.2	11.25	15.91	22.50	27.56	35.58	42.09	50.31					
DF26.250	•	5.5	12.50	17.68	25.00	30.62	39.53	46.77	55.90					

MODEL NO.	END CONNECTION	ORIFICE SIZE (mm)	FLOW CAPACITY IN LPM AT DIFFERENT PRESSURE							G/A DIMENSION. MM				
	1/4"		PRESSURE [BAR]							CONN.	H	H1	HEX	
SPRAY ANGLE 120°	BSP		0.5	1.0	2.0	3.0	5.0	7.0	10.0	1/4"	48	10	14	
DF18.475	•	2.4	2.37	3.36	4.75	5.82	7.51	8.89	10.62	Weight = XX gms. Approx				
DF18.650	•	2.8	3.25	4.60	6.50	7.96	10.28	12.16	14.53					
DF18.800	•	3.1	4.00	5.66	8.00	9.80	12.65	14.97	17.89					
DF28.100	•	3.5	5.00	7.07	10.00	12.25	15.81	18.71	22.36					
DF28.125	•	3.9	6.25	8.84	12.50	15.31	19.76	23.39	27.95					
DF28.160	•	4.4	8.00	11.31	16.00	19.60	25.30	29.93	35.78					
DF28.180	•	4.6	9.00	12.73	18.00	22.05	28.46	33.67	40.25					
DF28.200	•	4.9	10.00	14.14	20.00	24.49	31.62	37.42	44.72					
DF28.225	•	5.2	11.25	15.91	22.50	27.56	35.58	42.09	50.31					
DF28.250	•	5.5	12.50	17.68	25.00	30.62	39.53	46.77	55.90					

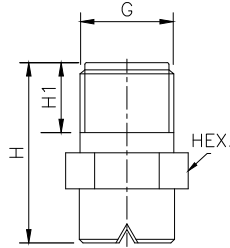

CA series Flat Spray Nozzles are designed for high pressure / high impact washing application. These nozzles are specially designed and machined with precision which allows even spray coverage and distribution. This results in effective and uniform cleaning action over the surface being processed. Flat spray nozzles are available in all steel grades, Plastics & other alloys. Spray angle range available from 45° to 120°

MODEL NO.	END CONNECTION		ORIFICE SIZE (mm)	FLOW CAPACITY IN LPM AT DIFFERENT PRESSURE							G/A DIMENSION. MM			
	1/4"	3/8"		PRESSURE [BAR]										
SPRAY ANGLE 45°	BSP	BSP		0.5	1.0	2.0	3.0	5.0	7.0	10.0	CONN.	H	H1	HEX
CA13.050	•		0.8	0.25	0.35	0.50	0.61	0.79	0.94	1.12	1/4"	25	9.7	15.5
CA13.075	•		1.0	0.37	0.53	0.75	0.92	1.19	1.40	1.68	Weight = XX gms. Approx			
CA13.100	•		1.2	0.50	0.71	1.00	1.22	1.58	1.87	2.24	3/8"	27	12	17
CA13.150	•		1.5	0.75	1.06	1.50	1.84	2.37	2.81	3.35	Weight = XX gms. Approx			
CA13.175	•		1.6	0.87	1.24	1.75	2.14	2.77	3.27	3.91				
CA13.200	•		1.7	1.00	1.41	2.00	2.45	3.16	3.74	4.47				
CA13.250	•		1.9	1.25	1.77	2.50	3.06	3.95	4.68	5.59				
CA13.300	•		2.1	1.50	2.12	3.00	3.67	4.74	5.61	6.71				
CA13.350	•		2.3	1.75	2.47	3.50	4.29	5.53	6.55	7.83				
CA13.400	•		2.4	2.00	2.83	4.00	4.90	6.32	7.48	8.94				
CA13.475	•		2.7	2.37	3.36	4.75	5.82	7.51	8.89	10.62				
CA13.650	•		3.1	3.25	4.60	6.50	7.96	10.28	12.16	14.53				
CA13.800	•		3.5	4.00	5.66	8.00	9.80	12.65	14.97	17.89				
CA23.100	•	•	3.9	5.00	7.07	10.00	12.25	15.81	18.71	22.36				
CA23.125	•	•	4.3	6.25	8.84	12.50	15.31	19.76	23.39	27.95				
CA23.160	•	•	4.9	8.00	11.31	16.00	19.60	25.30	29.93	35.78				
CA23.180	•	•	5.2	9.00	12.73	18.00	22.05	28.46	33.67	40.25				
CA23.200	•	•	5.5	10.00	14.14	20.00	24.49	31.62	37.42	44.72				
CA23.225	•	•	5.8	11.25	15.91	22.00	27.56	35.58	42.09	50.31				
CA23.250	•	•	6.1	12.50	17.68	25.00	30.62	39.53	46.77	55.90				
CA23.320		•	6.4	16.00	22.63	32.00	39.19	50.60	59.87	71.55				
CA23.400		•	7.8	20.00	28.28	40.00	48.99	63.25	74.83	89.44				

MODEL NO.	END CONNECTION		ORIFICE SIZE (mm)	FLOW CAPACITY IN LPM AT DIFFERENT PRESSURE							G/A DIMENSION. MM			
	1/4"	3/8"		PRESSURE [BAR]										
SPRAY ANGLE 60°	BSP	BSP		0.5	1.0	2.0	3.0	5.0	7.0	10.0	CONN.	H	H1	HEX
CA14.050	•		0.8	0.25	0.35	0.50	0.61	0.79	0.94	1.12	1/4"	27	9.7	15.5
CA14.075	•		1.0	0.37	0.53	0.75	0.92	1.19	1.40	1.68	Weight = XX gms. Approx			
CA14.100	•		1.2	0.50	0.71	1.00	1.22	1.58	1.87	2.24	3/8"	27	12	17
CA14.150	•		1.5	0.75	1.06	1.50	1.84	2.37	2.81	3.35	Weight = XX gms. Approx			
CA14.175	•		1.6	0.87	1.24	1.75	2.14	2.77	3.27	3.91				
CA14.200	•		1.7	1.00	1.41	2.00	2.45	3.16	3.74	4.47				
CA14.250	•		1.9	1.25	1.77	2.50	3.06	3.95	4.68	5.59				
CA14.300	•		2.1	1.50	2.12	3.00	3.67	4.74	5.61	6.71				
CA14.350	•		2.3	1.75	2.47	3.50	4.29	5.53	6.55	7.83				
CA14.400	•		2.4	2.00	2.83	4.00	4.90	6.32	7.48	8.94				
CA14.475	•		2.7	2.37	3.36	4.75	5.82	7.51	8.89	10.62				
CA14.650	•		3.1	3.25	4.60	6.50	7.96	10.28	12.16	14.53				
CA14.800	•		3.5	4.00	5.66	8.00	9.80	12.65	14.97	17.89				
CA24.100	•	•	3.9	5.00	7.07	10.00	12.25	15.81	18.71	22.36				
CA24.125	•	•	4.3	6.25	8.84	12.50	15.31	19.76	23.39	27.95				
CA24.160	•	•	4.9	8.00	11.31	16.00	19.60	25.30	29.93	35.78				
CA24.180	•	•	5.2	9.00	12.73	18.00	22.05	28.46	33.67	40.25				
CA24.200	•	•	5.5	10.00	14.14	20.00	24.49	31.62	37.42	44.72				
CA24.225	•	•	5.8	11.25	15.91	22.00	27.56	35.58	42.09	50.31				
CA24.250	•	•	6.1	12.50	17.68	25.00	30.62	39.53	46.77	55.90				
CA24.320		•	6.4	16.00	22.63	32.00	39.19	50.60	59.87	71.55				
CA24.400		•	7.8	20.00	28.28	40.00	48.99	63.25	74.83	89.44				

MODEL NO.	END CONNECTION		ORIFICE SIZE (mm)	FLOW CAPACITY IN LPM AT DIFFERENT PRESSURE							G/A DIMENSION. MM			
	1/4"	3/8"		PRESSURE [BAR]										
SPRAY ANGLE	BSP BSPT NPT	BSP BSPT NPT		0.5	1.0	2.0	3.0	5.0	7.0	10.0	CONN.	H	H1	HEX
90°														
CA16.050	•		0.8	0.25	0.35	0.50	0.61	0.79	0.94	1.12	1/4"	25	9.7	15.5
CA16.075	•		1.0	0.37	0.53	0.75	0.92	1.19	1.40	1.68	Weight = XX gms. Approx			
CA16.100	•		1.2	0.50	0.71	1.00	1.22	1.58	1.87	2.24	3/8"	27	12	17
CA16.150	•		1.5	0.75	1.06	1.50	1.84	2.37	2.81	3.35	Weight = XX gms. Approx			
CA16.175	•		1.6	0.87	1.24	1.75	2.14	2.77	3.27	3.91				
CA16.200	•		1.7	1.00	1.41	2.00	2.45	3.16	3.74	4.47				
CA16.250	•		1.9	1.25	1.77	2.50	3.06	3.95	4.68	5.59				
CA16.300	•		2.1	1.50	2.12	3.00	3.67	4.74	5.61	6.71				
CA16.350	•		2.3	1.75	2.47	3.50	4.29	5.53	6.55	7.83				
CA16.400	•		2.4	2.00	2.83	4.00	4.90	6.32	7.48	8.94				
CA16.475	•		2.7	2.37	3.36	4.75	5.82	7.51	8.89	10.62				
CA16.650	•		3.1	3.25	4.60	6.50	7.96	10.28	12.16	14.53				
CA16.800	•		3.5	4.00	5.66	8.00	9.80	12.65	14.97	17.89				
CA26.100	•	•	3.9	5.00	7.07	10.00	12.25	15.81	18.71	22.36				
CA26.125	•	•	4.3	6.25	8.84	12.50	15.31	19.76	23.39	27.95				
CA26.160	•	•	4.9	8.00	11.31	16.00	19.60	25.30	29.93	35.78				
CA26.180	•	•	5.2	9.00	12.73	18.00	22.05	28.46	33.67	40.25				
CA26.200	•	•	5.5	10.00	14.14	20.00	24.49	31.62	37.42	44.72				
CA26.225	•	•	5.8	11.25	15.91	22.00	27.56	35.58	42.09	50.31				
CA26.250	•	•	6.1	12.50	17.68	25.00	30.62	39.53	46.77	55.90				
CA26.320	•	•	6.4	16.00	22.63	32.00	39.19	50.60	59.87	71.55				
CA26.400	•	•	7.8	20.00	28.28	40.00	48.99	63.25	74.83	89.44				

MODEL NO.	END CONNECTION		ORIFICE SIZE (mm)	FLOW CAPACITY IN LPM AT DIFFERENT PRESSURE							G/A DIMENSION. MM			
	1/4"	3/8"		PRESSURE [BAR]										
SPRAY ANGLE	BSP BSPT NPT	BSP BSPT NPT		0.5	1.0	2.0	3.0	5.0	7.0	10.0	CONN.	H	H1	HEX
120°														
CA18.050	•		0.8	0.25	0.35	0.50	0.61	0.79	0.94	1.12	1/4"	25	9.7	15.5
CA18.075	•		1.0	0.37	0.53	0.75	0.92	1.19	1.40	1.68	Weight = XX gms. Approx			
CA18.100	•		1.2	0.50	0.71	1.00	1.22	1.58	1.87	2.24	3/8"	27	12	17
CA18.150	•		1.5	0.75	1.06	1.50	1.84	2.37	2.81	3.35	Weight = XX gms. Approx			
CA18.175	•		1.6	0.87	1.24	1.75	2.14	2.77	3.27	3.91				
CA18.200	•		1.7	1.00	1.41	2.00	2.45	3.16	3.74	4.47				
CA18.250	•		1.9	1.25	1.77	2.50	3.06	3.95	4.68	5.59				
CA18.300	•		2.1	1.50	2.12	3.00	3.67	4.74	5.61	6.71				
CA18.350	•		2.3	1.75	2.47	3.50	4.29	5.53	6.55	7.83				
CA18.400	•		2.4	2.00	2.83	4.00	4.90	6.32	7.48	8.94				
CA18.475	•		2.7	2.37	3.36	4.75	5.82	7.51	8.89	10.62				
CA18.650	•		3.1	3.25	4.60	6.50	7.96	10.28	12.16	14.53				
CA18.800	•		3.5	4.00	5.66	8.00	9.80	12.65	14.97	17.89				
CA28.100	•	•	3.9	5.00	7.07	10.00	12.25	15.81	18.71	22.36				
CA28.125	•	•	4.3	6.25	8.84	12.50	15.31	19.76	23.39	27.95				
CA28.160	•	•	4.9	8.00	11.31	16.00	19.60	25.30	29.93	35.78				
CA28.180	•	•	5.2	9.00	12.73	18.00	22.05	28.46	33.67	40.25				
CA28.200	•	•	5.5	10.00	14.14	20.00	24.49	31.62	37.42	44.72				
CA28.225	•	•	5.8	11.25	15.91	22.00	27.56	35.58	42.09	50.31				
CA28.250	•	•	6.1	12.50	17.68	25.00	30.62	39.53	46.77	55.90				
CA28.320	•	•	6.4	16.00	22.63	32.00	39.19	50.60	59.87	71.55				
CA28.400	•	•	7.8	20.00	28.28	40.00	48.99	63.25	74.83	89.44				

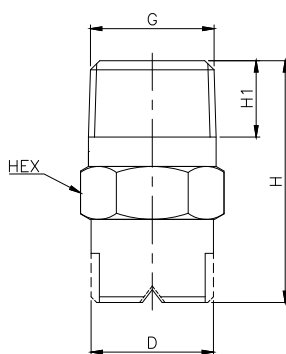

CP series Flat Spray Nozzles are designed for high pressure / high impact washing application. These nozzles are specially designed and machined with precision which allows even spray coverage and distribution. This results in effective and uniform cleaning action over the surface being processed. Flat spray nozzles are available in all steel grades, Plastics & other alloys. Spray angle range available from 15° to 120°. Standard design with self sealing thread connection. Stable spray angle, Uniform distribution of liquid, parabolical distribution of liquid.

Design : One piece construction, Non clogging type.

Application : Rinsing, Lubricating, Industrial washing machines, Cake washing in Centrifuge, CIP, Tray washing.

MODEL NO.	END CONNECTION	ORIFICE SIZE (mm)	FLOW CAPACITY IN LPM AT DIFFERENT PRESSURE							G/A DIMENSION. MM				
	1/4"		PRESSURE [BAR]							CONN.	H	H1	D	HEX
SPRAY ANGLE	BSP BSPT NPT		0.5	1.0	2.0	3.0	5.0	7.0	10.0	1/4"	25	10	13	14
15°										Weight (Metals) = XX gms. Approx				
CP11.050	•	0.8	0.25	0.35	0.50	0.61	0.79	0.94	1.12					
CP11.075	•	1.0	0.37	0.53	0.75	0.92	1.19	1.40	1.68					
CP11.100	•	1.2	0.50	0.71	1.00	1.22	1.58	1.87	2.24					
CP11.150	•	1.5	0.75	1.06	1.50	1.84	2.37	2.81	3.35					
CP11.175	•	1.6	0.87	1.24	1.75	2.14	2.77	3.27	3.91					
CP11.200	•	1.7	1.00	1.41	2.00	2.45	3.16	3.74	4.47					
CP11.250	•	1.9	1.25	1.77	2.50	3.06	3.95	4.68	5.59					
CP11.300	•	2.1	1.50	2.12	3.00	3.67	4.74	5.61	6.71					
CP11.350	•	2.3	1.75	2.47	3.50	4.29	5.53	6.55	7.83					
CP11.400	•	2.4	2.00	2.83	4.00	4.90	6.32	7.48	8.94					
CP11.475	•	2.7	2.37	3.36	4.75	5.82	7.51	8.89	10.62					
CP11.650	•	3.1	3.25	4.60	6.50	7.96	10.28	12.16	14.53					
CP11.800	•	3.5	4.00	5.66	8.00	9.80	12.65	14.97	17.89					
CP21.100	•	3.9	5.00	7.07	10.00	12.25	15.81	18.71	22.36					
CP21.125	•	4.3	6.25	8.84	12.50	15.31	19.76	23.39	27.95					
CP21.160	•	4.9	8.00	11.31	16.00	19.60	25.30	29.93	35.78					
CP21.180	•	5.2	9.00	12.73	18.00	22.05	28.46	33.67	40.25					
CP21.200	•	5.5	10.00	14.14	20.00	24.49	31.62	37.42	44.72					
CP21.225	•	5.8	11.25	15.91	22.00	27.56	35.58	42.09	50.31					
CP21.250	•	6.1	12.50	17.68	25.00	30.62	39.53	46.77	55.90					

MODEL NO.	END CONNECTION		ORIFICE SIZE (mm)	FLOW CAPACITY IN LPM AT DIFFERENT PRESSURE						G/A DIMENSION. MM					
	1/4"			PRESSURE [BAR]											
SPRAY ANGLE	BSP	BSPT								CONN.	H	H1	D	HEX	
30°	NPT	NPT		0.5	1.0	2.0	3.0	5.0	7.0	10.0	1/4"	25	10	13	14
CP12.050	•		0.8	0.25	0.35	0.50	0.61	0.79	0.94	1.12	1/4"	25	10	13	14
CP12.075	•		1.0	0.37	0.53	0.75	0.92	1.19	1.40	1.68	Weight (Metals) = XX gms. Approx				
CP12.100	•		1.2	0.50	0.71	1.00	1.22	1.58	1.87	2.24					
CP12.150	•		1.5	0.75	1.06	1.50	1.84	2.37	2.81	3.35					
CP12.175	•		1.6	0.87	1.24	1.75	2.14	2.77	3.27	3.91					
CP12.200	•		1.7	1.00	1.41	2.00	2.45	3.16	3.74	4.47					
CP12.250	•		1.9	1.25	1.77	2.50	3.06	3.95	4.68	5.59					
CP12.300	•		2.1	1.50	2.12	3.00	3.67	4.74	5.61	6.71					
CP12.350	•		2.3	1.75	2.47	3.50	4.29	5.53	6.55	7.83					
CP11.400	•		2.4	2.00	2.83	4.00	4.90	6.32	7.48	8.94					
CP11.475	•		2.7	2.37	3.36	4.75	5.82	7.51	8.89	10.62					
CP11.650	•		3.1	3.25	4.60	6.50	7.96	10.28	12.16	14.53					
CP11.800	•		3.5	4.00	5.66	8.00	9.80	12.65	14.97	17.89					
CP21.100	•		3.9	5.00	7.07	10.00	12.25	15.81	18.71	22.36					
CP21.125	•		4.3	6.25	8.84	12.50	15.31	19.76	23.39	27.95					
CP21.160	•		4.9	8.00	11.31	16.00	19.60	25.30	29.93	35.78					
CP21.180	•		5.2	9.00	12.73	18.00	22.05	28.46	33.67	40.25					
CP21.200	•		5.5	10.00	14.14	20.00	24.49	31.62	37.42	44.72					
CP21.225	•		5.8	11.25	15.91	22.00	27.56	35.58	42.09	50.31					
CP21.250	•		6.1	12.50	17.68	25.00	30.62	39.53	46.77	55.90					

MODEL NO.	END CONNECTION		ORIFICE SIZE (mm)	FLOW CAPACITY IN LPM AT DIFFERENT PRESSURE						G/A DIMENSION. MM					
	1/4"	3/8"		PRESSURE [BAR]											
SPRAY ANGLE	BSP	BSPT									CONN.	H	H1	D	HEX
45°	NPT	NPT		0.5	1.0	2.0	3.0	5.0	7.0	10.0	1/4"	25	10	13	14
CP13.050	•		0.8	0.25	0.35	0.50	0.61	0.79	0.94	1.12	1/4"	25	10	13	14
CP13.075	•		1.0	0.37	0.53	0.75	0.92	1.19	1.40	1.68	Weight (Metals) = XX gms. Approx				
CP13.100	•		1.2	0.50	0.71	1.00	1.22	1.58	1.87	2.24	3/8"	32	10	16	17
CP13.150	•		1.5	0.75	1.06	1.50	1.84	2.37	2.81	3.35	Weight (Metals) = XX gms. Approx				
CP13.175	•		1.6	0.87	1.24	1.75	2.14	2.77	3.27	3.91					
CP13.200	•		1.7	1.00	1.41	2.00	2.45	3.16	3.74	4.47					
CP13.250	•		1.9	1.25	1.77	2.50	3.06	3.95	4.68	5.59					
CP13.300	•		2.1	1.50	2.12	3.00	3.67	4.74	5.61	6.71					
CP13.350	•		2.3	1.75	2.47	3.50	4.29	5.53	6.55	7.83					
CP13.400	•		2.4	2.00	2.83	4.00	4.90	6.32	7.48	8.94					
CP13.475	•		2.7	2.37	3.36	4.75	5.82	7.51	8.89	10.62					
CP13.650	•		3.1	3.25	4.60	6.50	7.96	10.28	12.16	14.53					
CP13.800	•		3.5	4.00	5.66	8.00	9.80	12.65	14.97	17.89					
CP23.100	•	•	3.9	5.00	7.07	10.00	12.25	15.81	18.71	22.36					
CP23.125	•	•	4.3	6.25	8.84	12.50	15.31	19.76	23.39	27.95					
CP23.160	•	•	4.9	8.00	11.31	16.00	19.60	25.30	29.93	35.78					
CP23.180	•	•	5.2	9.00	12.73	18.00	22.05	28.46	33.67	40.25					
CP23.200	•	•	5.5	10.00	14.14	20.00	24.49	31.62	37.42	44.72					
CP23.225	•	•	5.8	11.25	15.91	22.00	27.56	35.58	42.09	50.31					
CP23.250	•	•	6.1	12.50	17.68	25.00	30.62	39.53	46.77	55.90					
CP23.320		•	6.4	16.00	22.63	32.00	39.19	50.60	59.87	71.55					
CP23.400		•	7.8	20.00	28.28	40.00	48.99	63.25	74.83	89.44					

MODEL NO.	END CONNECTION		ORIFICE SIZE (mm)	FLOW CAPACITY IN LPM AT DIFFERENT PRESSURE							G/A DIMENSION. MM				
	1/4"	3/8"		PRESSURE [BAR]											
SPRAY ANGLE	BSP BSPT NPT	BSP BSPT NPT									CONN.	H	H1	D	HEX
60°				0.5	1.0	2.0	3.0	5.0	7.0	10.0					
CP14.050	•		0.8	0.25	0.35	0.50	0.61	0.79	0.94	1.12	1/4"	25	10	13	14
CP14.075	•		1.0	0.37	0.53	0.75	0.92	1.19	1.40	1.68	Weight (Metals) = XX gms. Approx				
CP14.100	•		1.2	0.50	0.71	1.00	1.22	1.58	1.87	2.24	3/8"	32	10	16	17
CP14.150	•		1.5	0.75	1.06	1.50	1.84	2.37	2.81	3.35	Weight (Metals) = XX gms. Approx				
CP14.175	•		1.6	0.87	1.24	1.75	2.14	2.77	3.27	3.91					
CP14.200	•		1.7	1.00	1.41	2.00	2.45	3.16	3.74	4.47					
CP14.250	•		1.9	1.25	1.77	2.50	3.06	3.95	4.68	5.59					
CP14.300	•		2.1	1.50	2.12	3.00	3.67	4.74	5.61	6.71					
CP14.350	•		2.3	1.75	2.47	3.50	4.29	5.53	6.55	7.83					
CP14.400	•		2.4	2.00	2.83	4.00	4.90	6.32	7.48	8.94					
CP14.475	•		2.7	2.37	3.36	4.75	5.82	7.51	8.89	10.62					
CP14.650	•		3.1	3.25	4.60	6.50	7.96	10.28	12.16	14.53					
CP14.800	•		3.5	4.00	5.66	8.00	9.80	12.65	14.97	17.89					
CP24.100	•	•	3.9	5.00	7.07	10.00	12.25	15.81	18.71	22.36					
CP24.125	•	•	4.3	6.25	8.84	12.50	15.31	19.76	23.39	27.95					
CP24.160	•	•	4.9	8.00	11.31	16.00	19.60	25.30	29.93	35.78					
CP24.180	•	•	5.2	9.00	12.73	18.00	22.05	28.46	33.67	40.25					
CP24.200	•	•	5.5	10.00	14.14	20.00	24.49	31.62	37.42	44.72					
CP24.225	•	•	5.8	11.25	15.91	22.00	27.56	35.58	42.09	50.31					
CP24.250	•	•	6.1	12.50	17.68	25.00	30.62	39.53	46.77	55.90					
CP24.320		•	6.4	16.00	22.63	32.00	39.19	50.60	59.87	71.55					
CP24.400		•	7.8	20.00	28.28	40.00	48.99	63.25	74.83	89.44					

MODEL NO.	END CONNECTION		ORIFICE SIZE (mm)	FLOW CAPACITY IN LPM AT DIFFERENT PRESSURE							G/A DIMENSION. MM				
	1/4"	3/8"		PRESSURE [BAR]											
SPRAY ANGLE	BSP BSPT NPT	BSP BSPT NPT									CONN.	H	H1	D	HEX
90°				0.5	1.0	2.0	3.0	5.0	7.0	10.0					
CP16.050	•		0.8	0.25	0.35	0.50	0.61	0.79	0.94	1.12	1/4"	25	10	13	14
CP16.075	•		1.0	0.37	0.53	0.75	0.92	1.19	1.40	1.68	Weight (Metals) = XX gms. Approx				
CP16.100	•		1.2	0.50	0.71	1.00	1.22	1.58	1.87	2.24	3/8"	32	10	16	17
CP16.150	•		1.5	0.75	1.06	1.50	1.84	2.37	2.81	3.35	Weight (Metals) = XX gms. Approx				
CP16.175	•		1.6	0.87	1.24	1.75	2.14	2.77	3.27	3.91					
CP16.200	•		1.7	1.00	1.41	2.00	2.45	3.16	3.74	4.47					
CP16.250	•		1.9	1.25	1.77	2.50	3.06	3.95	4.68	5.59					
CP16.300	•		2.1	1.50	2.12	3.00	3.67	4.74	5.61	6.71					
CP16.350	•		2.3	1.75	2.47	3.50	4.29	5.53	6.55	7.83					
CP16.400	•		2.4	2.00	2.83	4.00	4.90	6.32	7.48	8.94					
CP16.475	•		2.7	2.37	3.36	4.75	5.82	7.51	8.89	10.62					
CP16.650	•		3.1	3.25	4.60	6.50	7.96	10.28	12.16	14.53					
CP16.800	•		3.5	4.00	5.66	8.00	9.80	12.65	14.97	17.89					
CP26.100	•	•	3.9	5.00	7.07	10.00	12.25	15.81	18.71	22.36					
CP26.125	•	•	4.3	6.25	8.84	12.50	15.31	19.76	23.39	27.95					
CP26.160	•	•	4.9	8.00	11.31	16.00	19.60	25.30	29.93	35.78					
CP26.180	•	•	5.2	9.00	12.73	18.00	22.05	28.46	33.67	40.25					
CP26.200	•	•	5.5	10.00	14.14	20.00	24.49	31.62	37.42	44.72					
CP26.225	•	•	5.8	11.25	15.91	22.00	27.56	35.58	42.09	50.31					
CP26.250	•	•	6.1	12.50	17.68	25.00	30.62	39.53	46.77	55.90					
CP26.320		•	6.4	16.00	22.63	32.00	39.19	50.60	59.87	71.55					
CP26.400		•	7.8	20.00	28.28	40.00	48.99	63.25	74.83	89.44					

MODEL NO.	END CONNECTION		ORIFICE SIZE (mm)	FLOW CAPACITY IN LPM AT DIFFERENT PRESSURE							G/A DIMENSION. MM				
	1/4"	3/8"		PRESSURE [BAR]											
SPRAY ANGLE	BSP BSPT NPT	BSP BSPT NPT		0.5	1.0	2.0	3.0	5.0	7.0	10.0	CONN.	H	H1	D	HEX
120°															
CP18.050	•		0.8	0.25	0.35	0.50	0.61	0.79	0.94	1.12	1/4"	25	10	13	14
CP18.075	•		1.0	0.37	0.53	0.75	0.92	1.19	1.40	1.68	Weight (Metals) = XX gms. Approx				
CP18.100	•		1.2	0.50	0.71	1.00	1.22	1.58	1.87	2.24	3/8"	32	10	16	17
CP18.150	•		1.5	0.75	1.06	1.50	1.84	2.37	2.81	3.35	Weight (Metals) = XX gms. Approx				
CP18.175	•		1.6	0.87	1.24	1.75	2.14	2.77	3.27	3.91					
CP18.200	•		1.7	1.00	1.41	2.00	2.45	3.16	3.74	4.47					
CP18.250	•		1.9	1.25	1.77	2.50	3.06	3.95	4.68	5.59					
CP18.300	•		2.1	1.50	2.12	3.00	3.67	4.74	5.61	6.71					
CP18.350	•		2.3	1.75	2.47	3.50	4.29	5.53	6.55	7.83					
CP18.400	•		2.4	2.00	2.83	4.00	4.90	6.32	7.48	8.94					
CP18.475	•		2.7	2.37	3.36	4.75	5.82	7.51	8.89	10.62					
CP18.650	•		3.1	3.25	4.60	6.50	7.96	10.28	12.16	14.53					
CP18.800	•		3.5	4.00	5.66	8.00	9.80	12.65	14.97	17.89					
CP28.100	•	•	3.9	5.00	7.07	10.00	12.25	15.81	18.71	22.36					
CP28.125	•	•	4.3	6.25	8.84	12.50	15.31	19.76	23.39	27.95					
CP28.160	•	•	4.9	8.00	11.31	16.00	19.60	25.30	29.93	35.78					
CP28.180	•	•	5.2	9.00	12.73	18.00	22.05	28.46	33.67	40.25					
CP28.200	•	•	5.5	10.00	14.14	20.00	24.49	31.62	37.42	44.72					
CP28.225	•	•	5.8	11.25	15.91	22.00	27.56	35.58	42.09	50.31					
CP28.250	•	•	6.1	12.50	17.68	25.00	30.62	39.53	46.77	55.90					
CP28.320		•	6.4	16.00	22.63	32.00	39.19	50.60	59.87	71.55					
CP28.400		•	7.8	20.00	28.28	40.00	48.99	63.25	74.83	89.44					

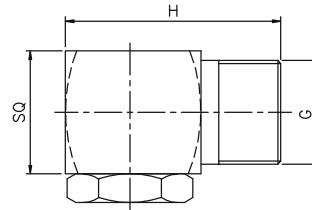

Tangential Entry Hollow Cone Standard Angle Spray Nozzles (Non-Clogging) :

BA series Hollow cone spray nozzles work on the tangential flow principle and are manufactured by machine tool operation from metal bar stock. This offers versatile construction of small sized nozzles. In addition nozzles can be made on request from any special material and alloys that are available as a bar stock. This flow pattern is essentially a circular ring of liquid. Hollow cone nozzles are best for application requiring good atomization of liquids at lower pressures or where quick heat transfer is needed. These nozzles also feature large and unobstructed flow passage which provide a relatively high resistance to clogging.

There are Following types of hollow cone nozzles.

- 1) Tangential Entry
- 2) Inline (Axial) Entry
- 3) Spiral Hollow cone.

Characteristic : High resistance to clogging

Design : Vaneless (Two Piece Construction) Non clogging

Application : Cooling & Washing of gas

MODEL NO.	END CONNECTION		INLET DIA. NOM (mm)	ORIFICE DIA. NOM (mm)	FLOW CAPACITY IN LPM AT DIFFERENT PRESSURE							G/A DIMENSION. MM		
	1/4"	3/8"			PRESSURE [BAR]									
SPRAY ANGLE	BSP	BSP			0.5	1.0	2.0	3.0	5.0	7.0	10.0	CONN.	H	SQ
60°														
BA14.075	•		1.3	1.4	0.37	0.53	0.75	0.92	1.19	1.40	1.68	1/4"	35	20
BA14.100	•		1.6	1.7	0.50	0.71	1.00	1.22	1.58	1.87	2.24	Weight (Metals) = 75 gms. Approx		
BA14.150	•		1.9	2.1	0.75	1.06	1.50	1.84	2.37	2.81	3.35	3/8"	35	20
BA14.175	•		2.0	2.3	0.87	1.24	1.75	2.14	2.77	3.27	3.91	Weight (Metals) = 75 gms. Approx		
BA14.200	•		2.2	2.4	1.00	1.41	2.00	2.45	3.16	3.74	4.47			
BA14.250	•		2.5	2.7	1.25	1.77	2.50	3.06	3.95	4.68	5.59			
BA14.300	•		2.7	3.0	1.50	2.12	3.00	3.67	4.74	5.61	6.71			
BA14.350	•	•	2.9	3.2	1.75	2.47	3.50	4.29	5.53	6.55	7.83			
BA14.400	•	•	3.1	3.5	2.00	2.83	4.00	4.90	6.32	7.48	8.94			
BA14.475	•	•	3.4	3.7	2.37	3.36	4.75	5.82	7.51	8.89	10.62			
BA14.650	•	•	4.0	4.4	3.25	4.60	6.50	7.96	10.28	12.16	14.53			
BA14.800	•	•	4.4	4.9	4.00	5.66	8.00	9.80	12.65	14.97	17.89			
BA24.100		•	4.9	5.5	5.00	7.07	10.00	12.25	15.81	18.71	22.36			
BA24.125		•	5.5	6.1	6.25	8.84	12.50	15.31	19.76	23.39	27.95			
BA24.160		•	6.2	6.9	8.00	11.31	16.00	19.60	25.30	29.93	35.78			
BA24.180		•	6.5	7.2	9.00	12.73	18.00	22.05	28.46	33.67	40.25			
BA24.200		•	6.9	7.7	10.0	14.14	20.00	24.49	31.62	37.42	44.72			
BA24.225		•	7.4	8.2	11.25	15.91	22.50	27.56	35.58	42.09	50.31			

MODEL NO.	END CONNECTION		INLET DIA. NOM (mm)	ORIFICE DIA. NOM (mm)	FLOW CAPACITY IN LPM AT DIFFERENT PRESSURE							G/A DIMENSION. MM		
	1/4"	3/8"			PRESSURE [BAR]									
SPRAY ANGLE	BSP	BSP										CONN.	H	SQ
90°					0.5	1.0	2.0	3.0	5.0	7.0	10.0			
BA16.075	●		1.3	1.4	0.37	0.53	0.75	0.92	1.19	1.40	1.68	1/4"	35	20
BA16.100	●		1.6	1.7	0.50	0.71	1.00	1.22	1.58	1.87	2.24	Weight (Metals) = 75 gms. Approx		
BA16.150	●		1.9	2.1	0.75	1.06	1.50	1.84	2.37	2.81	3.35	3/8"	35	20
BA16.175	●		2.0	2.3	0.87	1.24	1.75	2.14	2.77	3.27	3.91	Weight (Metals) = 75 gms. Approx		
BA16.200	●		2.2	2.4	1.00	1.41	2.00	2.45	3.16	3.74	4.47			
BA16.250	●		2.5	2.7	1.25	1.77	2.50	3.06	3.95	4.68	5.59			
BA16.300	●		2.7	3.0	1.50	2.12	3.00	3.67	4.74	5.61	6.71			
BA16.350	●	●	2.9	3.2	1.75	2.47	3.50	4.29	5.53	6.55	7.83			
BA16.400	●	●	3.1	3.5	2.00	2.83	4.00	4.90	6.32	7.48	8.94			
BA16.475	●	●	3.4	3.7	2.37	3.36	4.75	5.82	7.51	8.89	10.62			
BA16.650	●	●	4.0	4.4	3.25	4.60	6.50	7.96	10.28	12.16	14.53			
BA16.800	●	●	4.4	4.9	4.00	5.66	8.00	9.80	12.65	14.97	17.89			
BA26.100	●	●	4.9	5.5	5.00	7.07	10.00	12.25	15.81	18.71	22.36			
BA26.125	●	●	5.5	6.1	6.25	8.84	12.50	15.31	19.76	23.39	27.95			
BA26.160	●	●	6.2	6.9	8.00	11.31	16.00	19.60	25.30	29.93	35.78			
BA26.180	●	●	6.5	7.2	9.00	12.73	18.00	22.05	28.46	33.67	40.25			
BA26.200	●	●	6.9	7.7	10.0	14.14	20.00	24.49	31.62	37.42	44.72			
BA26.225	●	●	7.4	8.2	11.25	15.91	22.50	27.56	35.58	42.09	50.31			

MODEL NO.	END CONNECTION		INLET DIA. NOM (mm)	ORIFICE DIA. NOM (mm)	FLOW CAPACITY IN LPM AT DIFFERENT PRESSURE							G/A DIMENSION. MM		
	1/4"	3/8"			PRESSURE [BAR]									
SPRAY ANGLE	BSP	BSP										CONN.	H	SQ
120°					0.5	1.0	2.0	3.0	5.0	7.0	10.0			
BA18.075	●		1.3	1.4	0.37	0.53	0.75	0.92	1.19	1.40	1.68	1/4"	35	20
BA18.100	●		1.6	1.7	0.50	0.71	1.00	1.22	1.58	1.87	2.24	Weight (Metals) = 75 gms. Approx		
BA18.150	●		1.9	2.1	0.75	1.06	1.50	1.84	2.37	2.81	3.35	3/8"	35	20
BA18.175	●		2.0	2.3	0.87	1.24	1.75	2.14	2.77	3.27	3.91	Weight (Metals) = 75 gms. Approx		
BA18.200	●		2.2	2.4	1.00	1.41	2.00	2.45	3.16	3.74	4.47			
BA18.250	●		2.5	2.7	1.25	1.77	2.50	3.06	3.95	4.68	5.59			
BA18.300	●		2.7	3.0	1.50	2.12	3.00	3.67	4.74	5.61	6.71			
BA18.350	●	●	2.9	3.2	1.75	2.47	3.50	4.29	5.53	6.55	7.83			
BA18.400	●	●	3.1	3.5	2.00	2.83	4.00	4.90	6.32	7.48	8.94			
BA18.475	●	●	3.4	3.7	2.37	3.36	4.75	5.82	7.51	8.89	10.62			
BA18.650	●	●	4.0	4.4	3.25	4.60	6.50	7.96	10.28	12.16	14.53			
BA18.800	●	●	4.4	4.9	4.00	5.66	8.00	9.80	12.65	14.97	17.89			
BA28.100	●	●	4.9	5.5	5.00	7.07	10.00	12.25	15.81	18.71	22.36			
BA28.125	●	●	5.5	6.1	6.25	8.84	12.50	15.31	19.76	23.39	27.95			
BA28.160	●	●	6.2	6.9	8.00	11.31	16.00	19.60	25.30	29.93	35.78			
BA28.180	●	●	6.5	7.2	9.00	12.73	18.00	22.05	28.46	33.67	40.25			
BA28.200	●	●	6.9	7.7	10.0	14.14	20.00	24.49	31.62	37.42	44.72			

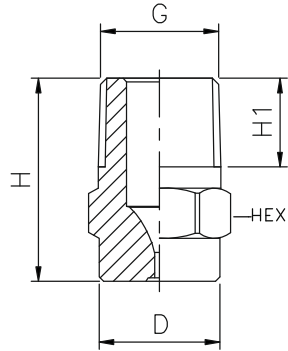

CL series Compact stream jet with a defined jet length owing to optimum flow geometry. Flow conditions are not affected by turbulence. A concentrated jet with high impact force is achieved. This is used for powerful punctiform impact, wherever concentrated jet power is vital.

- Characteristic** : A high efficiency and economical performance is obtained.
- Design** : One Piece Construction.
- Application** : For High pressure cleaning systems, Jet Cutting and separating.
- Features** : Optimized flow maximum jet power concentrated energy.

MODEL NO.	END CONNECTION		ORIFICE SIZE (mm)	FLOW CAPACITY IN LPM AT DIFFERENT PRESSURE							G/A DIMENSION. MM				
	1/4"	3/8"		PRESSURE [BAR]							CONN.	H	H1	D	HEX
SPRAY ANGLE 0°	BSP	BSP		0.5	1.0	2.0	3.0	5.0	7.0	10.0					
CL10.100	•		1.1	0.50	0.71	1.00	1.22	1.58	1.87	2.24	1/4"	22	10	13	14
CL10.150	•		1.3	0.75	1.06	1.50	1.84	2.37	2.81	3.35	Weight (Metals) = 18 gms. Approx				
CL10.175	•		1.4	0.87	1.24	1.75	2.14	2.77	3.27	3.91	3/8"	22	12	16	17
CL10.200	•		1.5	1.00	1.41	2.00	2.45	3.16	3.74	4.47	Weight (Metals) = 30 gms. Approx				
CL10.250	•		1.7	1.25	1.77	2.50	3.06	3.95	4.68	5.59					
CL10.300	•		1.9	1.50	2.12	3.00	3.67	4.74	5.61	6.71					
CL10.350	•	•	2.0	1.75	2.47	3.50	4.29	5.53	6.55	7.83					
CL10.400	•	•	2.1	2.00	2.83	4.00	4.90	6.32	7.48	8.94					
CL10.475	•	•	2.3	2.37	3.36	4.75	5.82	7.51	8.89	10.62					
CL10.650	•	•	2.7	3.25	4.60	6.50	7.96	10.28	12.16	14.53					
CL10.800	•	•	3.0	4.00	5.66	8.00	9.80	12.65	14.97	17.89					
CL20.100	•	•	3.4	5.00	7.07	10.00	12.25	15.81	18.71	22.36					
CL20.125	•	•	3.7	6.25	8.84	12.50	15.31	19.76	23.39	27.95					
CL20.160	•	•	4.2	8.00	11.31	16.00	19.60	25.30	29.93	35.78					
CL20.180	•	•	4.5	9.00	12.73	18.00	22.05	28.46	33.67	40.25					
CL20.200	•	•	5.7	10.00	14.14	20.00	24.49	31.62	37.42	44.72					
CL20.225	•	•	5.0	11.25	15.91	22.50	27.56	35.58	42.09	50.31					
CL20.250	•	•	5.3	12.50	17.68	25.00	30.62	39.53	46.77	55.90					

DESIGN FEATURES

- Effective, economical way to Circulate liquids in closed or open tanks
- No Moving parts
- Inherently clog resistant
- Requires minimal maintenance
- Nozzles operation creates multiplying effect on fluid flow



Plastic Versions



Metal Versions

SPRAY CHARACTERISTICS

- Cone -shaped plume Flow rates: 26.7 to 12000 L/min (motive)
- The volume of discharge liquid will be 3-5 times greater than the motive liquid pumped.
- It's unique venturi design ensures proper mixing of tank Solution.

Eductors have a unique venturi design which enables smaller pumps to circulate large volumes of tank solution. The eductor will circulate four to five gallons of solution for each gallon pumped. Eductors are used for mixing chemicals, suspending solids, adjusting pH, "sweeping" debris or sludge toward a filter intake and many other useful applications.

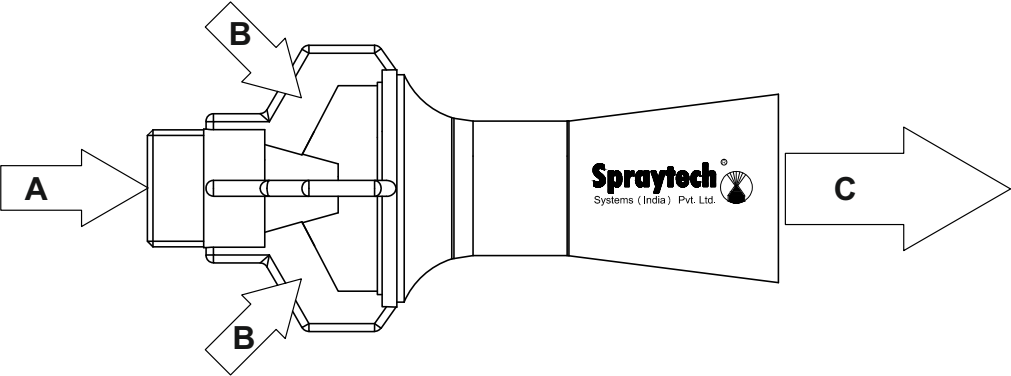

A = Inlet Flow Rate
B = Entrained Flow Rate
C = (A+B) Out Flow

Application

- | | | |
|---------------------|----------------|------------------------|
| • Plating Tanks | • Pulp Tanks | • Anodizing Tanks |
| • Phosphating Tanks | • Sludge Tanks | • Cooling Towers |
| • Fertilizer tanks | • Paint Booths | • Decorative Fountains |

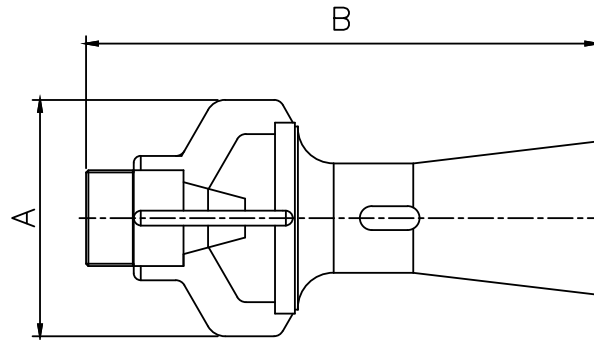

Plastic Versions

PLASTIC									
Connection Size BSP	Model Number	Motive Flow Rate LPM @ BAR						Dimensions (mm)	
		0.7 bar	1 bar	1.5 bar	2 bar	3 bar	4 bar	A	B
1/4	TE30	11.54	13.79	16.89	19.50	23.88	27.58	30.8	82.0
3/8	TE80	30.94	37.00	45.30	52.30	64.00	74.00	52.0	114.7
1/2	TE93	35.50	42.43	51.96	60.00	73.48	84.85	71.0	161.0
3/4	TE120	44.37	53.03	64.95	75.00	91.86	106.07	71.7	164.3
1	TE240	88.74	106.00	129.90	150.00	183.71	212.13	--	--
1 1/2	TE350	133.11	159.10	195.86	225.00	275.57	318.20	115.4	254.1

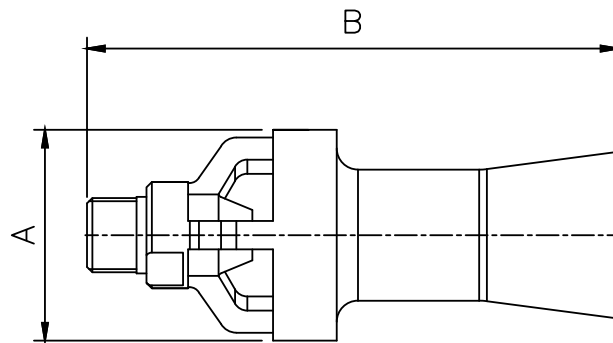

Metal Versions

METAL										
Connection Size BSP / BSPT / NPT	Model Number	Motive Flow Rate LPM @ BAR						Dimensions (mm)		
		0.7 bar	1 bar	1.5 bar	2 bar	3 bar	5 bar	A	B	
Threaded	1/4	TE35	13.6	16.2	19.92	23	28.1	36.3	36	80
	3/8	TE73	27.8	33.2	40.70	47	57.5	74.3	49.5	115
	1/2	TE120	45.8	54.2	66.4	76.7	93.94	121.2	59.5	150
	3/4	TE150	57.2	68.3	83.7	96.7	118.4	152.9	69.5	167
	1	TE240	88.74	106.7	129.9	150	183.7	237.1	89	241
	1 1/2	TE340	129.5	154.8	189.6	219	268.2	346.2	114	252
	2	TE620	236.5	282.1	345.5	399	488.6	630.8	134	290
	3	TE1500	572.0	683.7	837.4	967	1184.3	1528.9	174	375.5
Flange End	4	TE2510	952.5	1138.4	1394.3	1610	1971.8	2545.6	--	--
	6	TE6010	2271.7	2715.2	3325.5	3840	4703.0	6071.5	--	--
	8	TE10050	3804.0	4546.7	5568.5	6430	7875.1	10166.7	--	--

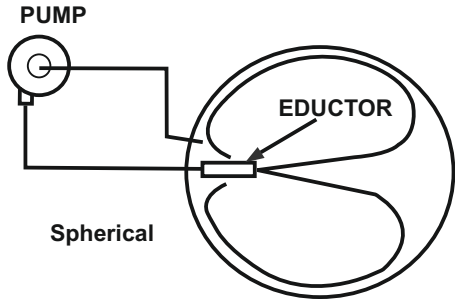

Figure 1
Eductor in a round tank



Figure 2
Eductors in a tank providing mixing.

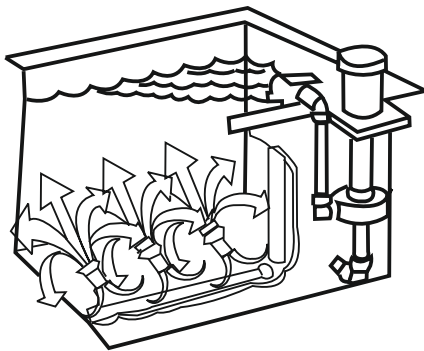

Figure 3
Multiple eductor assembly



Figure 4
Eductors in a tank maintaining suspension and mixing of solids.

MOUNTING

An eductor can be mounted in any position. The supply line and manifold piping to multiple eductors must be sized to supply uniform pressure to each eductor. It is important that the eductor be positioned within the tank to insure the free flow of liquid to be mixed into and out of the units. The greatest agitation occurs within the discharge plume; therefore, the discharge end should be aimed towards the most remote part of the tank. On the other hand, the intake end of the unit must be just far enough from the tank corner or wall to allow the free flow of liquid into the suction openings.

Tank shape and size influence the placement and number of eductors required to maintain even agitation. With a spherical tank, a single eductor mounted as shown in the Figure 1 illustration makes the best use of the mixing characteristics of the eductor. With no corners to impede liquid flow, the liquid circulates evenly.

In simple mixing application in a cylindrical, square or rectangular tank, not a plating tank, the angular intersection of stagnation in these areas. A single eductor mounted as shown in Figure 2 will minimize this. For high agitation, use of multiple eductors are recommended as shown in Figure 3.

A slight downward angle of the eductors can be helpful in maintaining the velocity at the tank bottom which is necessary to keep solids in suspension for easier removal by a filter system. (See Figure 4)

SH SERIES PIPE HOLDERS

SH series pipe holders are user-friendly and convenient solution for fixing spray manifolds onto tunnels walls in surface treatment plants. They are easy to assemble, excellent fastening and low cost. The single clip type is suitable for plastic pipes and double clip is suitable for metallic pipes.

Typical application : Holding pipe, Piping assembly

Pipe size : 3/4", 1", 1 1/4", 1 1/2", 2"

Materials

Body : Polypropylene (20%-25% glass filled)

Clamp : SS 304 / SS 316

Colour : L. Blue

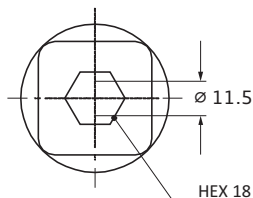

SH series holder body is designed to be fastened to the tunnel wall by means of one M10 bolt with 17 mm hexagonal head.

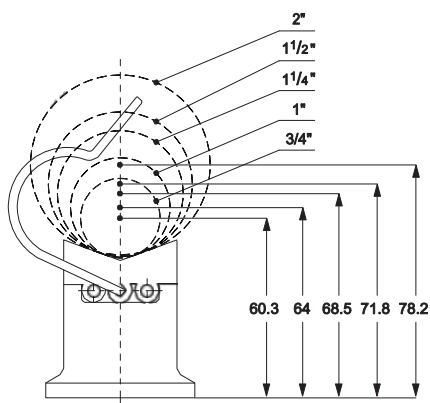

The drawing shows the distances of the pipe central axis from the wall for different pipe sizes assembled onto the pipe holder.

CODE		PIPE SIZE (inch)
Single Clamp	Double Clamp	
SH1E	SH2E	3/4"
SH1F	SH2F	1"
SH1G	SH2G	1 1/4"
SH1H	SH2H	1 1/2"
SH1K	SH2K	2"



Single Clamp

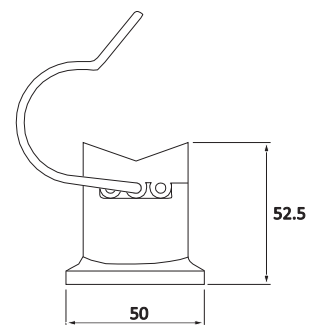

Double Clamp

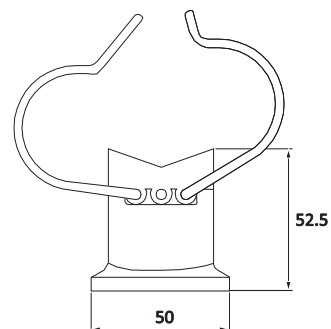

ACC501, ACC502 & ACC503 Camlock couplings are a very popular solution for quick assembly/disassembly also provides ease of operation.

- Thread size 3/4", 1", 1 1/4", 1 1/2"
- Thread specification BSP, NPT
- Typical applications Quick installation in piping, sanitary installation applications.

Materials

Body : Polypropylene (20% - 25% glass filled)

Lever : SS 316

O-ring : NBR (standard)
 Viton (optional)
 EPDM (optional)

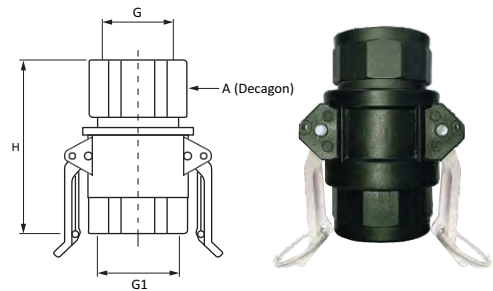

ACC501

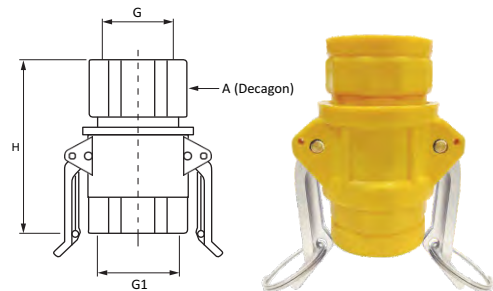

ACC502

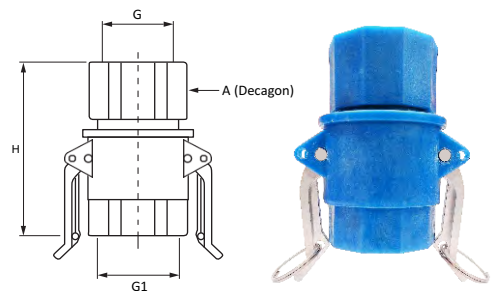

ACC503

MODEL NO	G (inch) BSP (F)	G1 (inch) BSP (F)	H (mm)	A (mm)	RATING (bar)	COLOUR	WEIGHT APPROX (grams)
ACC501.P2G.XE	3/4"	3/4"	98	48	10	BLACK	207.0
ACC501.P2G.XF	1"	1"	98	48	8	BLACK	207.0
ACC502.P2G.XF	1"	1"	98	48	10	YELLOW	235.0
ACC502.P2G.XG	1 1/4"	1 1/4"	98	48	8	YELLOW	235.0
ACC503.P2G.XG	1 1/4"	1 1/4"	110	58	15	BLUE	267.0
ACC503.P2G.XH	1 1/2"	1 1/2"	110	58	12	BLUE	267.0

CAMLOCK COUPLING - INSTALLATION



1. Install the threaded portion at each end

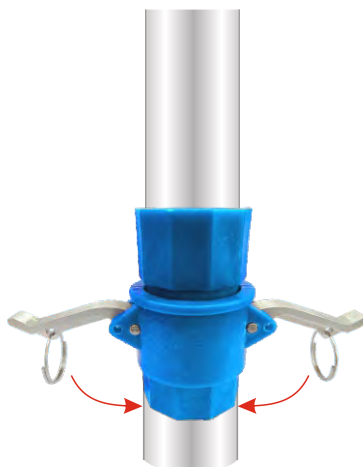

2. Pull levers down and fasten



3. Fix the clip

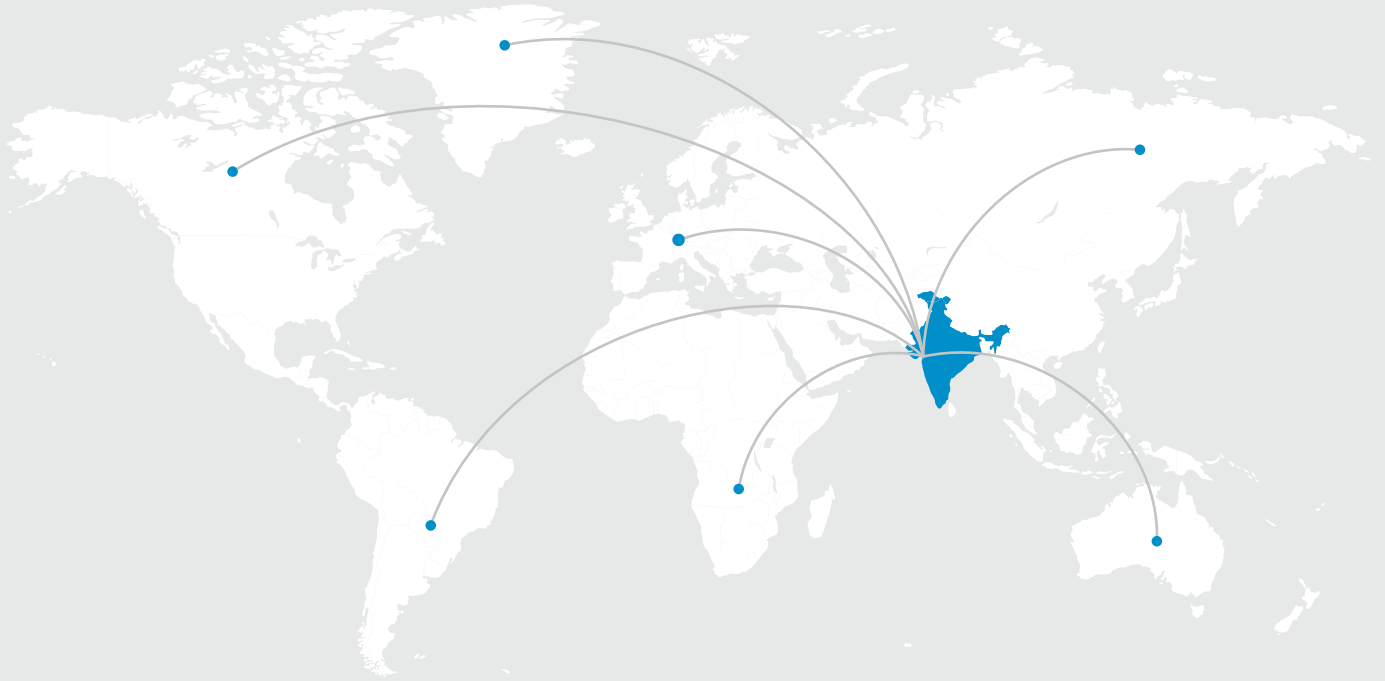

OUR BRANCHES

Regd. Office (Mumbai) :

Spraytech House, Plot A-132, Road No. 23, Spraytech Circle,
Wagle Indl. Estate, Thane (W) - 400 604. Mumbai Maharashtra, (India)
Tel. : 91-022-2582 8929 / 2735 / 2736
E-mail :- sales@spraytechindia.com
sales1@spraytechindia.com

Rabale Plant 1 (Navi Mumbai) :

Spraytech Systems (I) Pvt. Ltd., Plot No.: R-513, MIDC, TTC Industrial
Area, Rabale, Navi Mumbai - 400 701.

Rabale Plant 2 (Navi Mumbai) :

R-446, T.T.C. Industrial Area, MIDC Rabale,
Navi Mumbai - 400 701.

Branch Office (Pune) :

White House, Survey no. 161, Near
Bhosale Garden Hadapsar, Pune 411028

Indapur Plant (Pune) :

Spraytech Systems (I) Pvt. Ltd., Plot No.: A-5, Indapur Five Star
Industrial Area, Village - Loni Devkar Balpudi, Tal. - Indapur,
Dist. - Pune. - 413132



Visit Website